

HAND BRAKE VALVE (961 723/724 XXX 0)

WABCO has been made aware of cases of improper handling of the WABCO Hand Brake Valves which resulted in an unsecured locking into the parking position.

DESCRIPTION

WABCO has received a small number of reports of Hand Brake Valves equipped with "PRESSURE POINT" and "STOP" technology, where the hand lever was not securely locked into the parking position. As a root cause WABCO identified, in some cases, an improper handling of the Hand Brake Valve and in other cases, an excessive wear or damage of inner components caused by improper use of the Hand Brake Valve over a longer period of time.

Under these conditions, a secure locking of the handle in the parking position might not be ensured, and the vehicle parking brake might be unintentionally released.

Lack of attention of the user when activating the parking brake can potentially result in situation such as improper engaged lever. Wrong handling during activation or releasing operation could lead to damage of internal components.

Examples of misuses that could lead to either increase wear or deformation or internal component damages:

- non axial or partial lifting of the handle while operating (refer to the diagrams below)
- overload / excessive side force applied while operating the handle

RECOMMENDATION

Therefore WABCO strongly recommends that you increase the awareness of customers who are using the Hand Brake Valve equipped with "PRESSURE POINT" and "STOP" technology (refer to the drawings below) about the importance of proper usage.

In case any abnormality in locking function is detected by the user at any time (e.g. not smooth movement, increased friction, free play etc.), WABCO recommends the replacement of such misused Hand Brake Valve.

Fig. 1. WABCO HBV technologies

HBV with „STOP” & „PRESSURE POINT” technology – solutions comparison

„PRESSURE POINT” technology

„STOP” technology

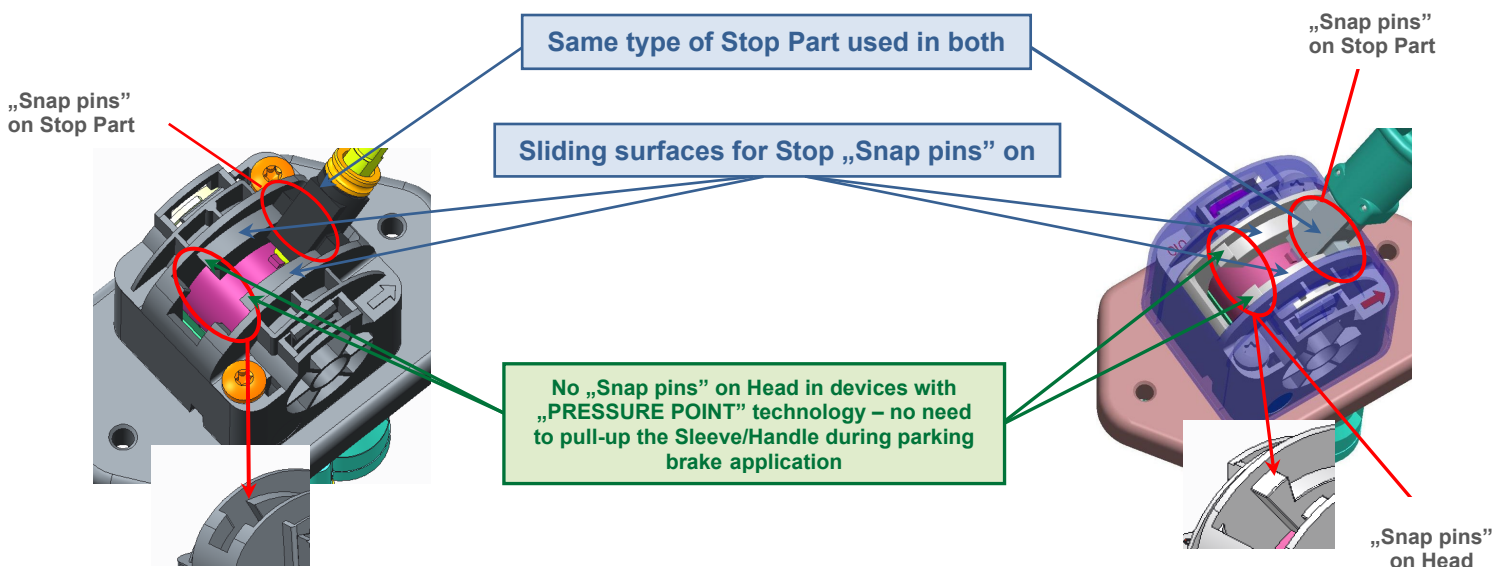

POTENTIALLY AFFECTED WABCO HAND BRAKE VALVES

The Hand Brake Valve variants listed below (mainly from families 961 723/724 xxx 0) are subject to this Product Advisory (please refer to the table)

Table 1: Part numbers

100306460	9611700550	9617230267	9617230690	9617231237	9617231720	9617241070
4006075770	9611700560	9617230270	9617230700	9617231240	9617231730	9617242000
4006512700	9611700600	9617230280	9617230710	9617231250	9617232000	9617242010
8840075160	9611700750	9617230290	9617230720	9617231260	9617232007	9617242040
8840075300	9617230002	9617230300	9617230730	9617231270	9617232010	9617242050
8840075310	9617230010	9617230310	9617230740	9617231300	9617232017	9617242070
8840150390	9617230012	9617230320	9617230750	9617231320	9617232030	9617242080
8840151470	9617230017	9617230330	9617230760	9617231340	9617232037	9617242090
8840152800	9617230020	9617230340	9617230810	9617231360	9617232040	9617242100
8840152810	9617230027	9617230360	9617230820	9617231370	9617232050	9617242110
8840153080	9617230030	9617230370	9617230850	9617231380	9617232080	9617242120
8840155450	9617230040	9617230380	9617230860	9617231390	9617232090	9617242130
8840155470	9617230042	9617230390	9617230920	9617231400	9617232100	9617242140
8840155490	9617230050	9617230400	9617230930	9617231430	9617232120	9617242150
8840156790	9617230050	9617230410	9617231000	9617231440	9617232127	9617242160
8840160320	9617230052	9617230420	9617231007	9617231450	9617232130	9617242170
8840160330	9617230057	9617230430	9617231020	9617231470	9617232140	9617242240
8840160340	9617230070	9617230440	9617231040	9617231490	9617232150	9617242250
8840160350	9617230080	9617230470	9617231047	9617231500	9617232160	9617242330
8840160360	9617230082	9617230490	9617231060	9617231510	9617232170	9617247000
8840160370	9617230090	9617230500	9617231067	9617231520	9617232250	9617247950
8840160380	9617230092	9617230510	9617231070	9617231530	9617232260	9617247960
8840161610	9617230097	9617230520	9617231077	9617231540	9617232270	9617249252
8840162710	9617230107	9617230530	9617231080	9617231550	9617236112	9617249262
8840185520	9617230110	9617230540	9617231087	9617231560	9617239202	9617249272
8840185530	9617230120	9617230550	9617231090	9617231570	9617239222	PRO6450000
8840559990	9617230140	9617230560	9617231100	9617231580	9617239232	PRO6450010
8840568680	9617230150	9617230570	9617231110	9617231590	9617239302	PRO6450020
8840583810	9617230160	9617230580	9617231120	9617231620	9617239312	PRO6450030
8845025070	9617230170	9617230590	9617231150	9617231630	9617239620	PRO6450040
8845025210	9617230190	9617230640	9617231160	9617231640	9617239622	PRO6450050
9611700000	9617230210	9617230650	9617231170	9617231650	9617241020	PRO6450060
9611700010	9617230220	9617230660	9617231180	9617231660	9617241030	PRO6450070
9611700020	9617230230	9617230670	9617231200	9617231670	9617241040	PRO6450080
9611700030	9617230250	9617230680	9617231220	9617231680	9617241050	PRO6450090
9611700040	9617230260	9617230690	9617231230	9617231690	9617241060	

Fig.2 Hand Brake Valve proper handling

HBV with „STOP” technology – activation description

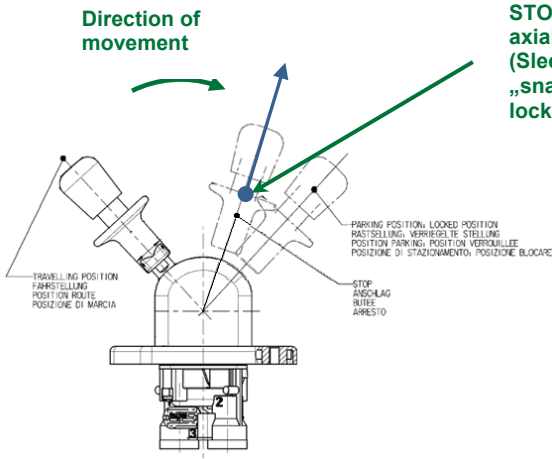

STOP position – after 60 degree of movement, axial pull up of the Sleeve/Handle is required (Sleeve/Handle must be lifted up to overcome „snap pins” presented on head) to reach locking position.

Non axial or not full lifting of the sleeve / handle or overload / side overload lifting applied on the handle will result in increased wear / deformation / breaking of „snap pins” on head and / or Stop Part. Handle should be moved fully till the end of the stroke position before sleeve / handle release.

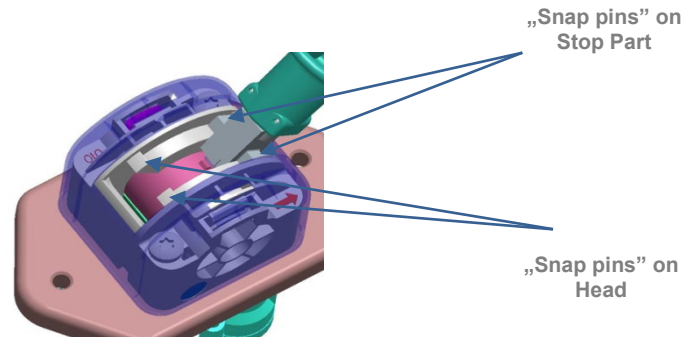

HBV with „STOP” technology – release description

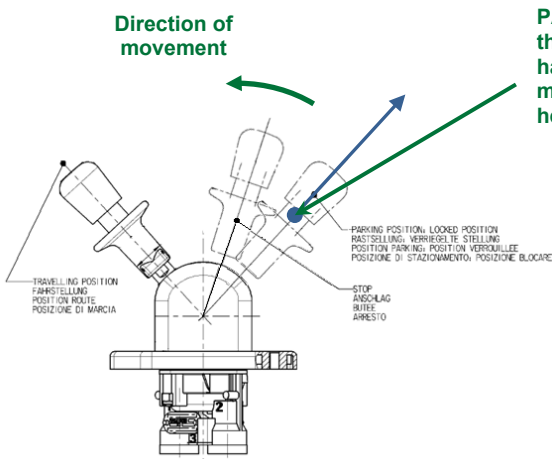

PARKING/LOCKING position – axial pull up of the Sleeve / Handle is required to release handle from locking position (Sleeve/Handle must be lifted up to overcome „snap pins” on head).

Non axial or not full lifting of the sleeve / handle or overload / side overload lifting applied on the handle will result in increased wear / deformation / breaking of “snap pins” on head and / or Stop Part.

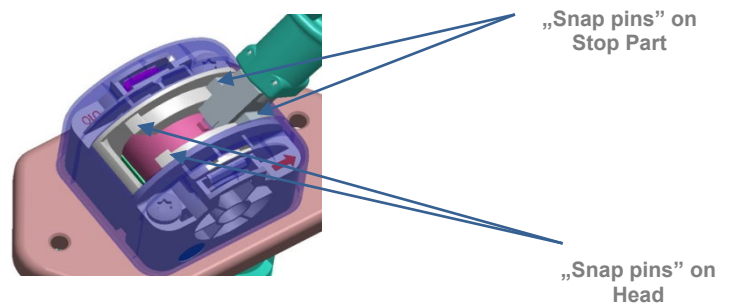

HBV with „PRESSURE POINT” technology – activation description

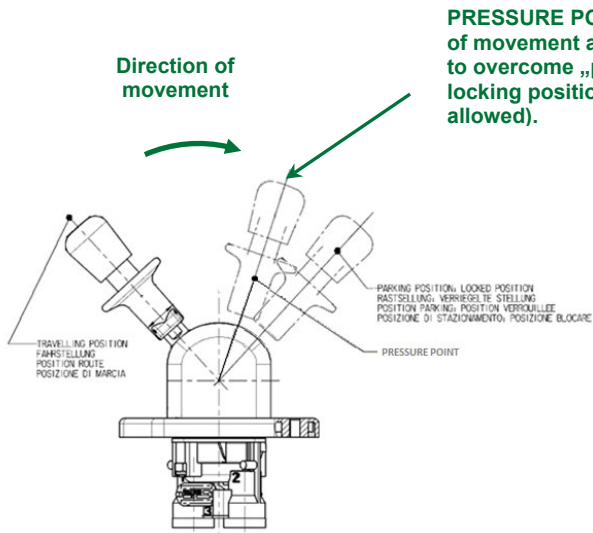

PRESSURE POINT position – after ~67 degree of movement a higher pulling force is required to overcome „pressure point” to reach the locking position (Sleeve/Handle lifting up not allowed).

Lifting of the sleeve / handle will result in increased risk of not securely locking into parking position. Handle should be moved „smoothly” and fully till the end of the stroke position, without lifting.

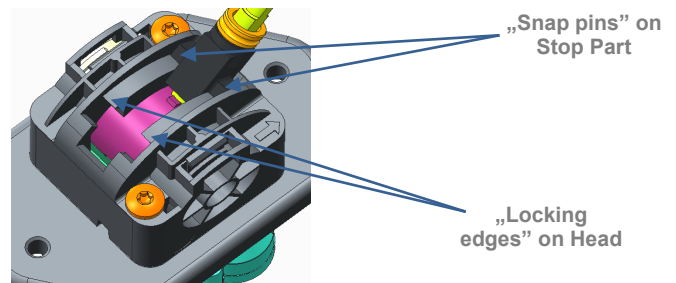

HBV with „PRESSURE POINT” technology – release description

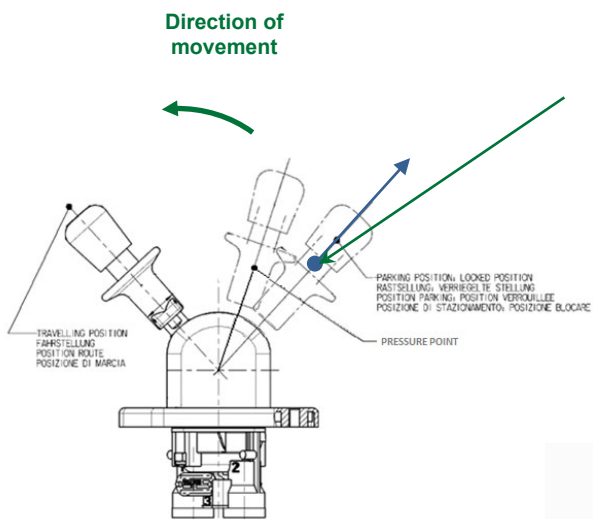

PARKING/LOCKING position – pull up of the Sleeve/Handle is required to release the handle from the locking position

(Sleeve/Handle must be lifted up to overcome „locking edges” on head).

Non fully lifting of the sleeve / handle or lifting with overload / side overload applied on Handle will result in increased wear / deformation / breaking of „snap pins” on Stop Part or increased wear / deformation of „locking edges” on the Head.

