

Mobilized by
WABCO Trailer
Solutions



Relay Emergency Valve

Advanced Relay Emergency Valve Range for All Trailer Applications



The Difference

- ZF's new generation trailer Relay Emergency Valve (REV) features integrated fittings and adjustable predominance functionality.
- Product safety guarantee with full ECE-R 13/1 compliance (actuator response time ≤ 0.44 s.Q).
- Valve incorporates a silencer which reduces exhaust noise (fulfilling UN/ECE regulation 51 and ADR-83/00-external noise regulations).
- Integrated predominance function enables delivery pressure adjustment for enhanced truck-trailer compatibility.

Value to Customers

- Fully interchangeable – mounting interface is identical across the range
- Full function coverage – existing range functionality maintained
- Reduced assembly costs – fully dressed valves with brass or composite fittings
- Unified delivery ports to M16x1.5 for all variants

Technical Features

The Relay Emergency Valve (REV) controls the trailer service brake in line with a truck's braking demands. Featuring rapid response times, the REV fulfils safety emergency braking function requirements with automatic braking when the supply line is disconnected. A predominance function enables the adjustment of delivery pressure to be higher than control pressure in the range of zero to 0.7 bar. The purpose of the predominance function is to improve truck and trailer compatibility with the ECE-R13 envelope and is available for both ABS and non-ABS applications. EBS applications only use valves without predominance functionality.



Product Variants

3 port valve

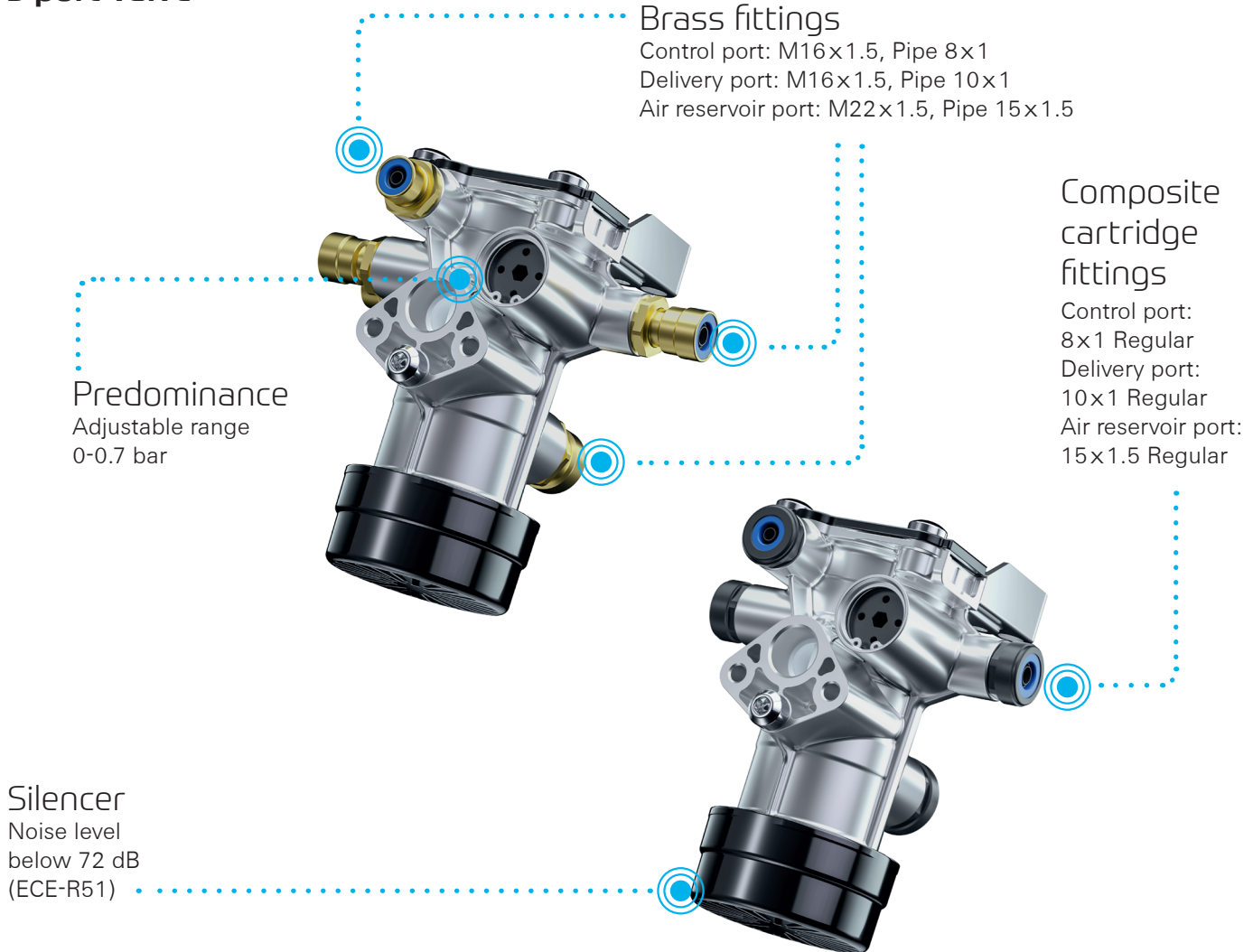

Number of ports (Delivery)	TRV Flange	Predominance	ELV Flange	Brass Fittings	Composite Fittings	Silencer	TRV PN	REV PN	Valve Description
3 port	x	x				x		971 002 020 0	Relay Emergency Valve
3 port	x	x		x		x		971 002 021 0	Relay Emergency Valve
3 port	x	x				x	963 001 013 0	971 002 022 0	Relay Emergency Valve with Release Valve
3 port	x	x		x		x	963 001 013 0	971 002 023 0	Relay Emergency Valve with Release Valve
3 port	x	x			x	x		971 002 024 0	Relay Emergency Valve
3 port	x					x		971 002 025 0	Relay Emergency Valve (w/o predominance for EBS)

Product Variants

3 port valve with flange

Brass fittings

Control port: M16x1.5, Pipe 8x1
 Delivery port: M16x1.5, Pipe 10x1
 Air reservoir port: M22x1.5, Pipe 15x1.5

Predominance

Adjustable range
 0-0.7 bar

TRV

Pre-installed
 Trailer Release
 Valve (TRV)

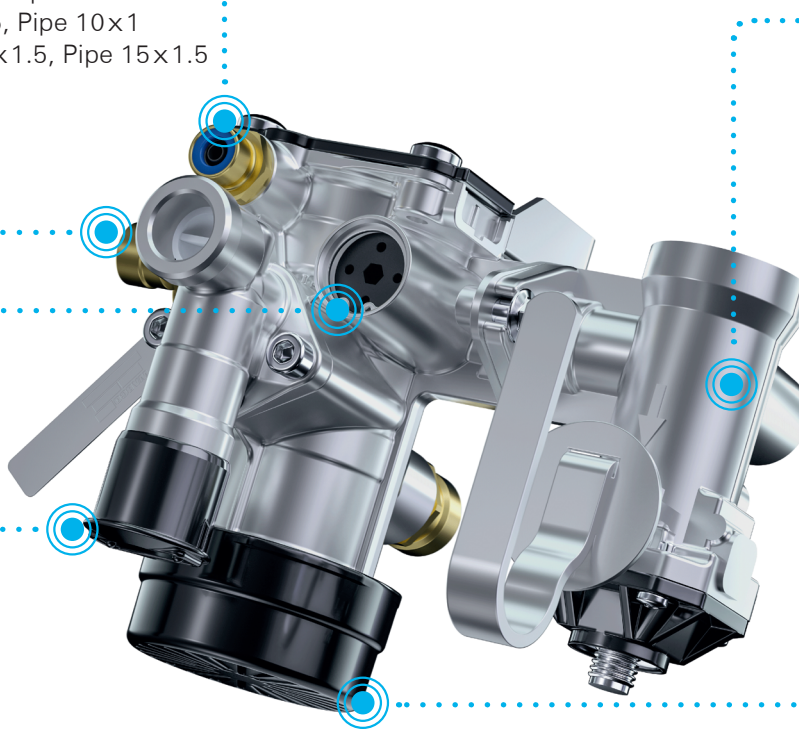

ELV

Pre-installed
 Empty Load
 Valve (ELV)

Silencer

Noise level below
 72 dB (ECE-R51)

Number of ports	TRV Flange	Pre-dominance	ELV Flange	Brass Fittings	Com-posite Fittings	Silencer	TRV PN	ELV PN	REV PN	Valve Description
3 port	x	x	x			x			971 002 030 0	Relay Emergency Valve
3 port	x	x	x	x		x			971 002 031 0	Relay Emergency Valve
3 port	x	x	x			x	963 001 013 0		971 002 032 0	Relay Emergency Valve with Release Valve
3 port	x	x	x	x		x	963 001 013 0		971 002 033 0	Relay Emergency Valve with Release Valve
3 port	x	x	x			x	963 001 013 0	475 604 041 0	971 002 034 0	Relay Emergency Valve with Release Valve and ELV
3 port	x	x	x	x		x	963 001 013 0	475 604 041 0	971 002 035 0	Relay Emergency Valve with Release Valve and ELV
3 port	x	x	x		x	x			971 002 036 0	Relay Emergency Valve
3 port	x	x	x			x	963 001 013 0	475 604 043 0 w/o release function	971 002 037 0	Relay Emergency Valve with Release Valve and ELV w/o release function

Product Variants

4 and 6-port valve

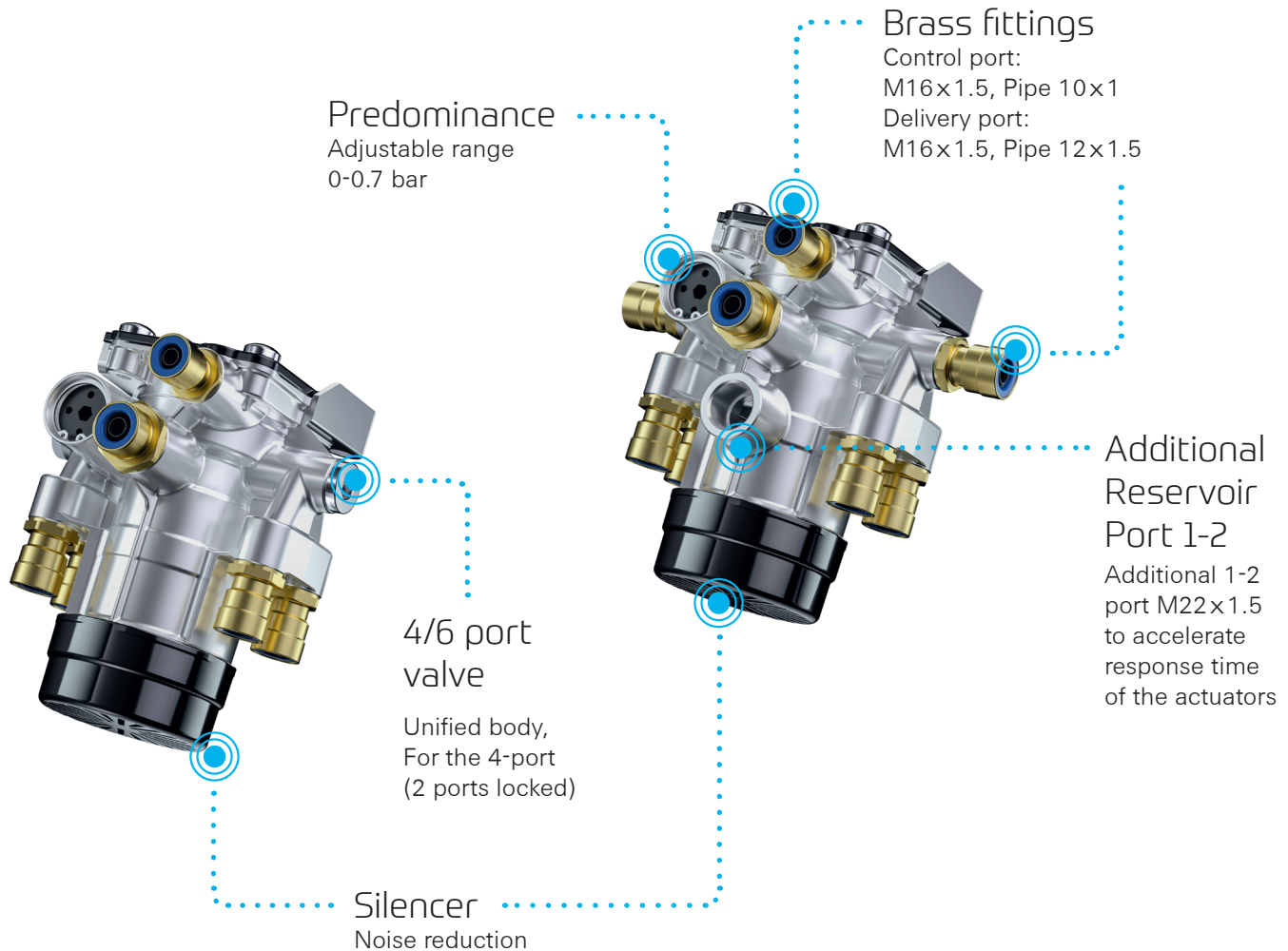

Number of ports (Delivery)	TRV Flange	Pre-dominance	Brass Fittings	Composite Fittings	Silencer	REV PN	Valve Description
4 port	x	x			x	971 002 040 0	Relay Emergency Valve
4 port	x	x	x		x	971 002 041 0	Relay Emergency Valve
4 port					x	971 002 042 0	Relay Emergency Valve (w/o predominance for EBS)
6 port	x	x			x	971 002 060 0	Relay Emergency Valve
6 port	x	x	x		x	971 002 061 0	Relay Emergency Valve

Technical Specification

Description	REV Details (all variants)
Working medium	Pressurized air
Thermal range of operation	-40 °C to +65 °C
Nominal working pressure	9 bar
Predominance function adjustment pressure range	0 to 0.7 bar
Reservoir filling crack-off (check valve)	0.5 bar maximum
Relay crack-off	0.3 bar max. (+65 °C to -20 °C) 0.35 bar max. (-20 °C to -40 °C)
Relay ratio	> 1 (Applicable for control pressure above 4 bar)
Emergency brake applied pressure	Min 2.5 bar
Emergency brake release pressure	Max 4.0 bar
Service life	10 years (1 million km)
Installation	Exhaust facing down (vertical) +/- 60° allowed
Noise level	Below 72 dB (for 3 port variants)

Brake characteristic

Emergency Braking

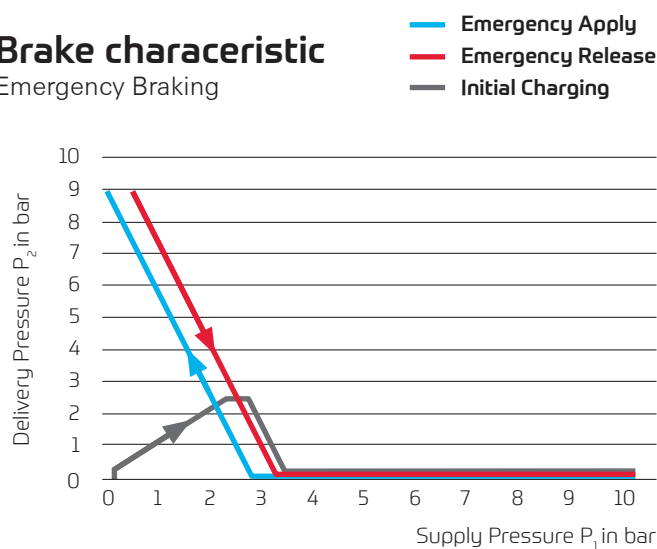

Predominance adjustment

Service Brake Application

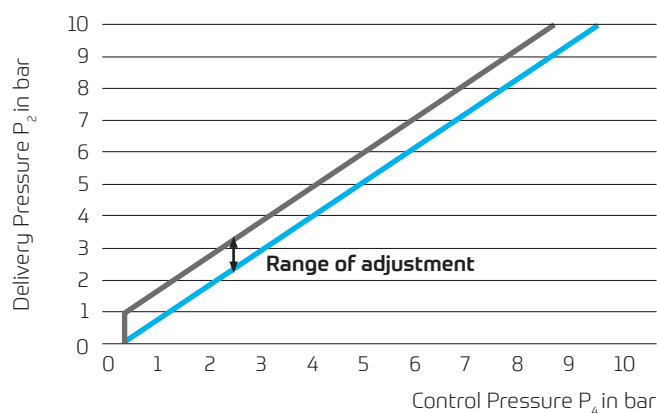

Cross reference table | 3 port variant

Existing part number	Number of delivery ports	without fittings	with brass fittings	with integrated composite fittings
971 002 300 0	3 port	971 002 020 0	971 002 021 0	971 002 024 0
971 002 300 7	3 port	971 002 020 0	971 002 021 0	971 002 024 0
971 002 301 0	3 port	971 002 025 0		
971 002 303 0	3 port	971 002 025 0		
971 002 304 0	3 port	971 002 020 0	971 002 021 0	971 002 024 0
971 002 305 0	3 port	971 002 020 0	971 002 021 0	971 002 024 0
971 002 307 0	3 port	971 002 025 0		
971 002 307 7	3 port	971 002 025 0		
971 002 308 0	3 port	971 002 020 0	971 002 021 0	971 002 024 0
971 002 805 0	3 port	971 002 025 0		
971 002 700 0	3 port	971 002 022 0	971 002 023 0	
971 002 700 7	3 port	971 002 022 0	971 002 023 0	
971 002 701 0	3 port	971 002 022 0	971 002 023 0	
971 002 701 7	3 port	971 002 022 0	971 002 023 0	
971 002 702 0	3 port	971 002 022 0	971 002 023 0	
971 002 703 0	3 port	971 002 022 0	971 002 023 0	
971 002 704 0	3 port	971 002 022 0	971 002 023 0	

Technical Specification

Cross reference table | 3 port variant with flange for Empty Load Valve (ELV)

Existing part number	Number of delivery ports	without fittings	with brass fittings	with integrated composite fittings
971 002 150 0	3 port	971 002 030 0	971 002 031 0	971 002 036 0
971 002 150 7	3 port	971 002 030 0	971 002 031 0	971 002 036 0
971 002 155 0	3 port	971 002 030 0	971 002 031 0	971 002 036 0
971 002 000 0	3 port	971 002 030 0	971 002 031 0	971 002 036 0
971 002 000 7	3 port	971 002 030 0	971 002 031 0	971 002 036 0
971 002 200 0	3 port	971 002 030 0	971 002 031 0	971 002 036 0
971 002 200 7	3 port	971 002 030 0	971 002 031 0	971 002 036 0
971 002 531 0	3 port	971 002 032 0	971 002 033 0	
971 002 531 7	3 port	971 002 032 0	971 002 033 0	
971 002 532 0	3 port	971 002 032 0	971 002 033 0	
971 002 533 0	3 port	971 002 032 0	971 002 033 0	
971 002 533 7	3 port	971 002 032 0	971 002 033 0	
971 002 547 0	3 port	971 002 032 0	971 002 033 0	
971 002 548 0	3 port	971 002 032 0	971 002 033 0	
971 002 570 0	3 port	971 002 034 0	971 002 035 0	
971 002 580 0	3 port	971 002 034 0	971 002 035 0	
971 002 620 0	3 port	971 002 037 0		

Cross reference table | 4 and 6 port variant

Existing part number	Number of delivery ports	without fittings	with brass fittings
971 005 000 0	4 port	971 002 040 0	971 002 041 0
971 005 002 0	4 port	971 002 040 0	971 002 041 0
971 005 000 0	4 port	971 002 042 0 without predominance	–
971 005 002 0	4 port	971 002 042 0 without predominance	–
971 002 151 0	6 port	971 002 060 0	971 002 061 0
971 002 152 0	6 port	971 002 060 0	971 002 061 0
971 002 152 7	6 port	971 002 060 0	971 002 061 0
971 002 157 0	6 port	971 002 060 0	971 002 061 0
971 002 157 7	6 port	971 002 060 0	971 002 061 0
971 002 203 0	6 port	971 002 060 0	971 002 061 0

For further details, please contact your local representative

About us

ZF, which acquired WABCO Holdings Inc. on May 29, 2020, is a global technology company supplying systems for passenger cars, commercial vehicles and industrial technology, enabling the next generation of mobility.

ZF allows vehicles to see, think and act. In the four technology domains of Vehicle Motion Control, Integrated Safety, Automated Driving, and Electric Mobility, ZF offers comprehensive product and software solutions for established vehicle manufacturers and newly emerging transport and mobility service providers.

ZF electrifies a wide range of vehicle types. With its products, the company contributes to reducing emissions, protecting the climate and enhancing safe mobility.