

<- SAFETY CHARACTERISTICS	0
<- SIGNIFICANT CHARACTERISTICS	0
<- CUSTOMER INTERFACE	0

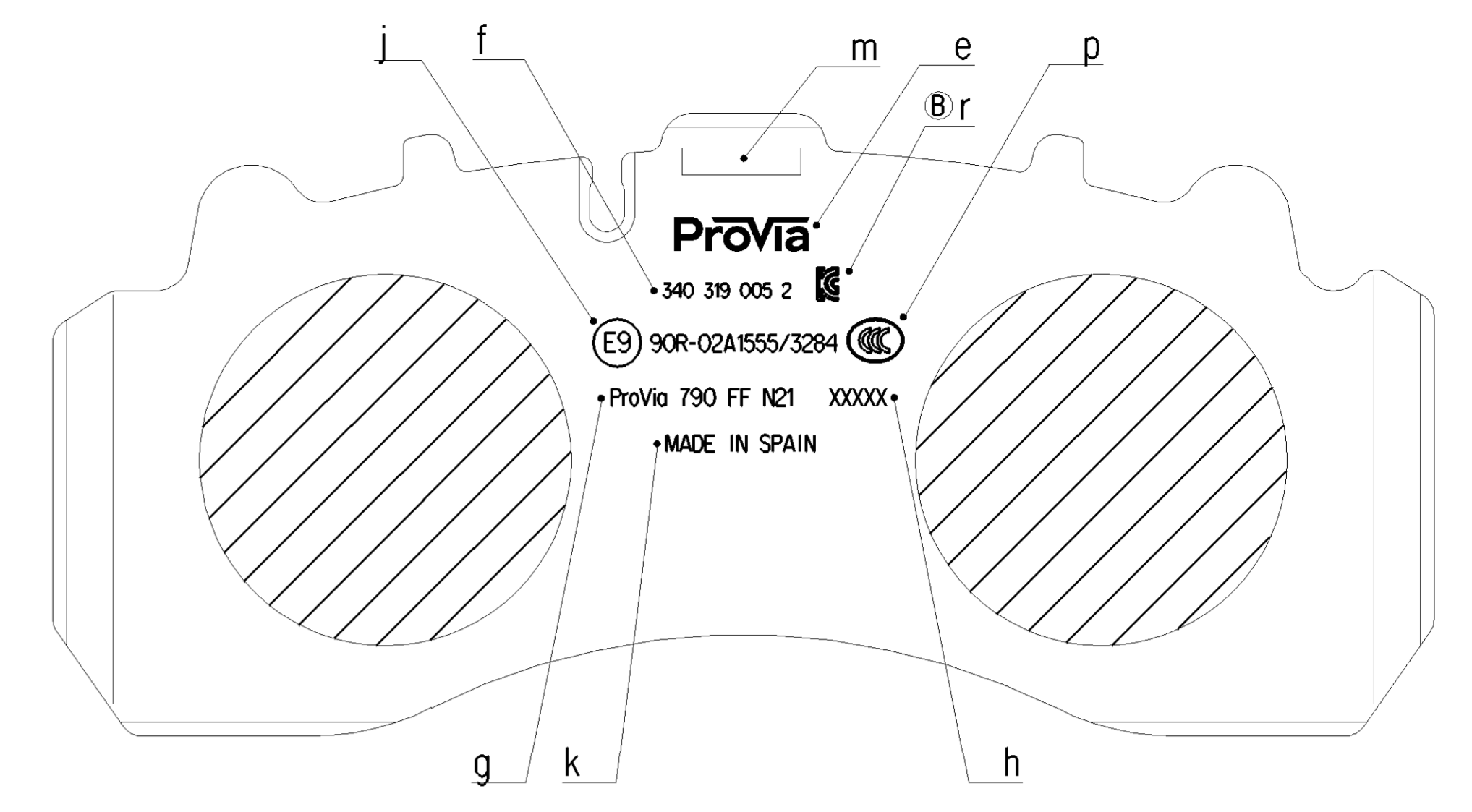
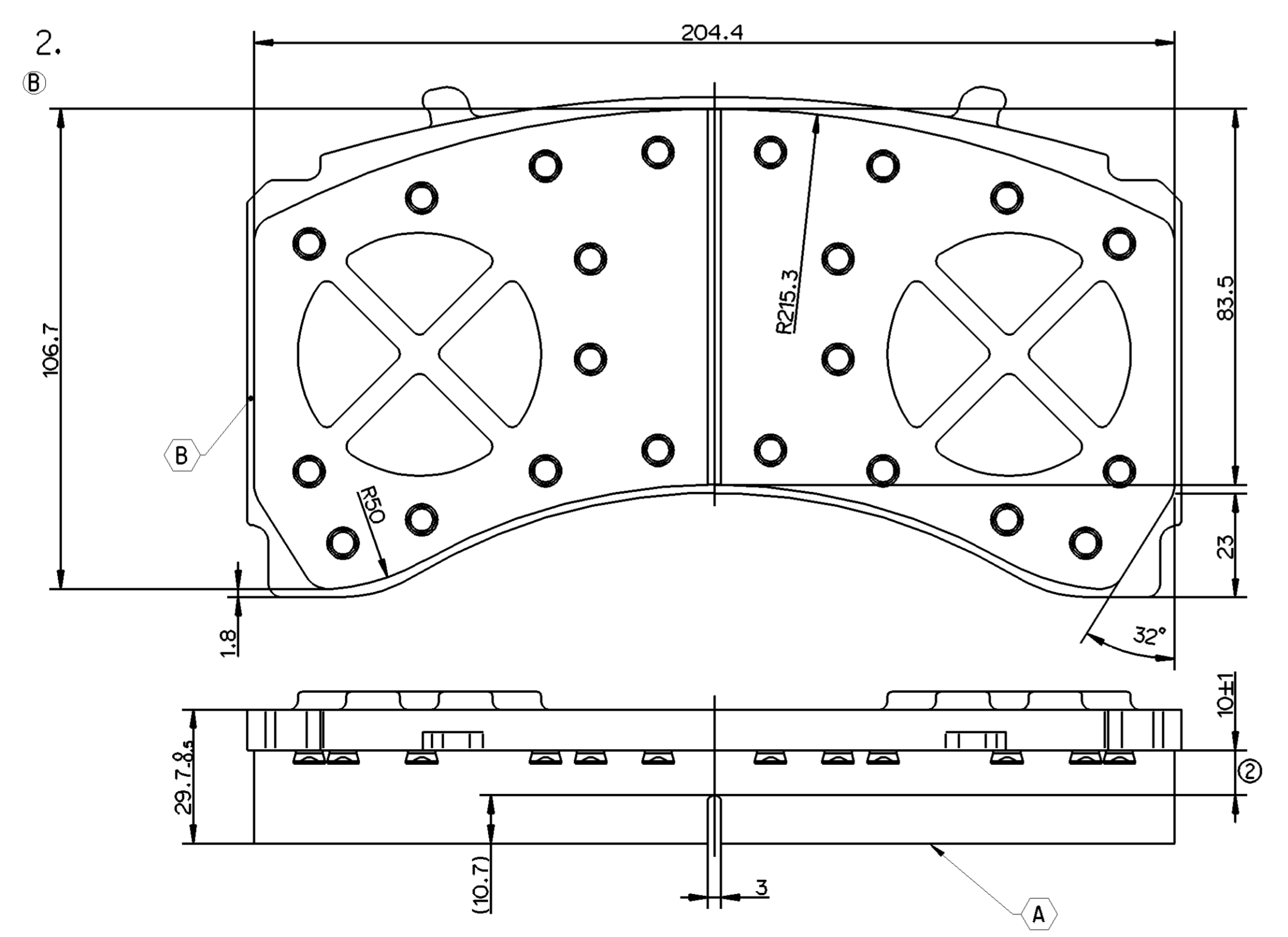
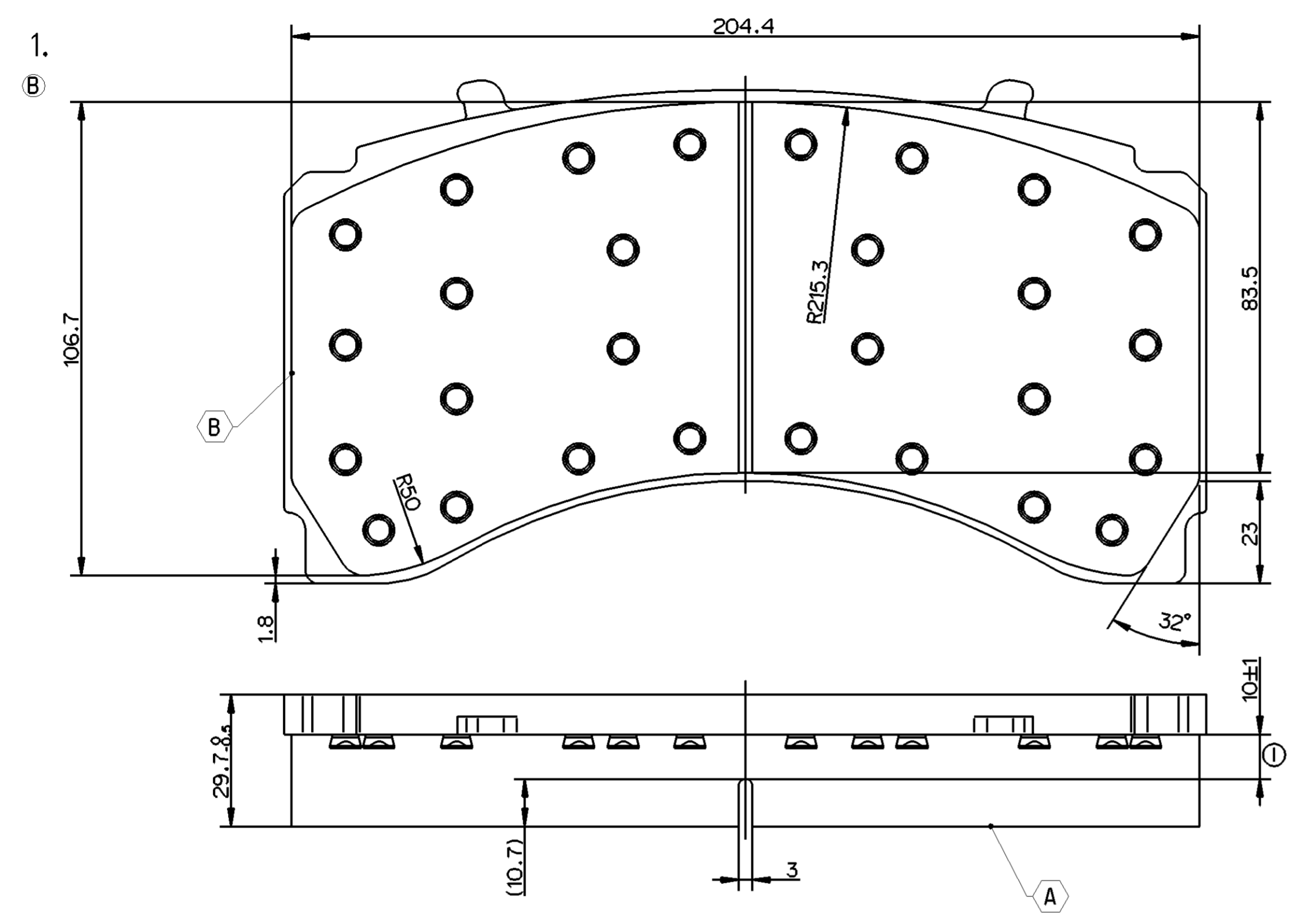

DRAFT FOR TEXT AREAS EXPLANATION ONLY. DRAFT CAN BE DIFFERENT TO THE REAL PART.
HEIGHT OF CHARACTERS AND POSITION OF THE MARKING MAY BE ACC. TO THE SHAPE OF THE BACKING PLATE.

IDENTIFICATION	DESIGNATION	KIND OF MARKING	COLOUR	SIZE OF TYPES	REMARKS	
e	PROVIA - LOGO	TAMPON / UV-BRANDING	WHITE	HEIGHT 6±1		
f	PROVIA - SET NUMBER	B INKJET PRINTING	WHITE	B HEIGHT 2.5±1		
g	FRICTION MATERIAL CODE			HEIGHT 3±1		CORRESPONDING WVA NUMBER TO BE ADDED IN THE LOCATION MENTIONED
h	NUMBER OF WVA					
j	NUMBER OF ECE R90					
k	COUNTRY OF ORIGIN					
m	TRACEABILITY CODE	STAMPING B				
n	EAC - LOGO	ERIC STICKER PRINTING	BLACK	HEIGHT 6	LOGO TO BE ADDED IN PACKAGING BOX STICKER	
p	CCC - LOGO	B INKJET PRINTING	WHITE	SIZE 8X6.3±1		
r	KC - LOGO	B INKJET PRINTING	B WHITE	B HEIGHT 6±1		

- A MAX. 10% LACQUER PERMITTED, WITHOUT MOULD SKIN. (ACC. TO FINISHING CODE)
- B FIRMLY ATTACHED BURR AROUND PAD CONTOUR PERMITTED, MUST NOT PROTRUDE BEYOND BACKING PLATE

POS.	NAME	NUMBER OF WVA	QUANTITY
1	BRAKE PAD	29298	2
2	BRAKE PAD	29299	2

General Specification: JED-334-1 - Size ISO 14405 LP

Further Technical Data: 340 319 005 2

Doc. Code: 014 Sheet: 1 To 3

Copyright WABCO®

Date: 2021-09-28

Signature: *[Signature]*

Drawn: *[Signature]*

Checked: *[Signature]*

Expert: *[Signature]*

Thomas Blasing

Material No.: 340 319 005 2

Date of first issue: 2021-05-17

Doc. Code: 005 EN 1/2

Mass: 11.29 kg

Scale: 1:1

Size: CAD System

ECN-No.: 509293

Revision: 10x B

Techn. Resp.: 6928_AM

Replacement for: -

1) Tolerance Class Applied Crossmarked

Non è permesso copiare o riprodurre questo documento, né utilizzare il contenuto o i dati contenuti in esso, senza permesso scritto dalla WABCO. È vietata espressamente la ristampa o l'uso non autorizzato. Toute réimpression ou utilisation non autorisée sans la permission écrite de la WABCO est formellement interdite. Toute réimpression ou utilisation non autorisée sans la permission écrite de la WABCO est formellement interdite.

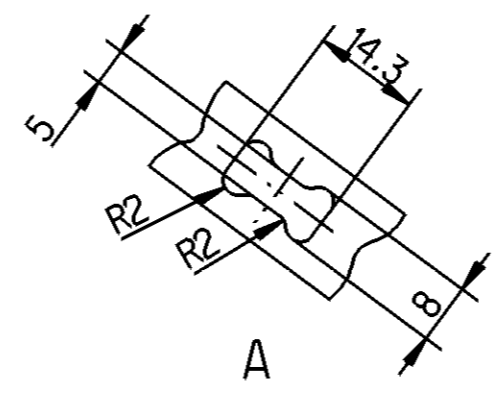
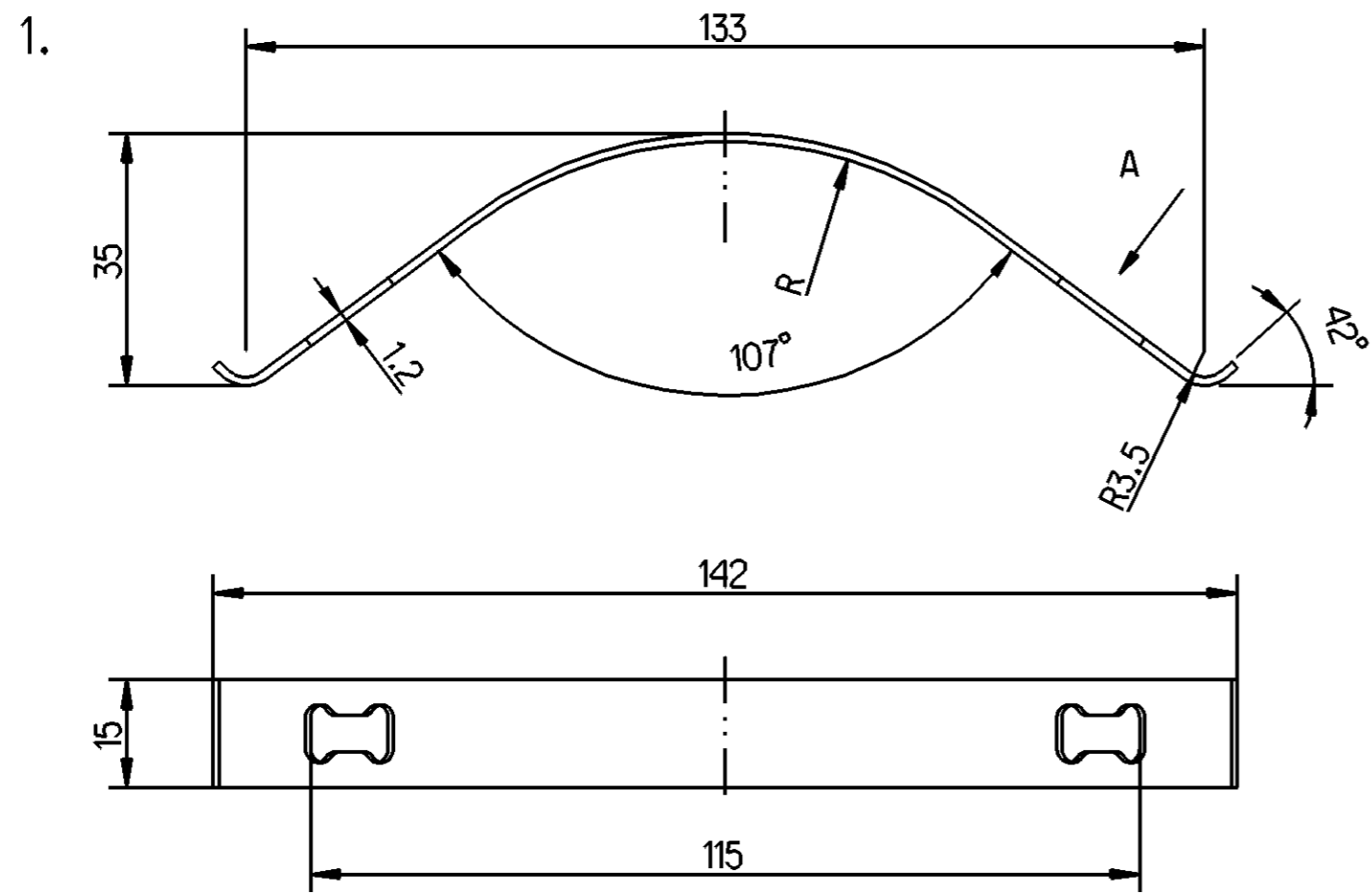

Non e permesso copiare, o terzi o riprodurre questo documento, ne utilizzare il contenuto o renderlo comunque noto o terzi senza autorizzazione esplicita. Ogni infrazione costituisce un evidente abuso e comportera il risarcimento dei danni subiti. E' fatta riserva di tutti i diritti derivanti da brevetti o modelli.

Copying of this document and giving it to others and the use or communication of the contents thereof, are forbidden without express authority. Contravention of this restriction will constitute an evident abuse and result in a liability to the payment of damages. All rights are reserved in the event of the grant of patent or registration of a utility model or design. This document is the subject of copyright.

Toute communication ou reproduction de ce document, toute exploitation ou communication de son contenu sont interdites, sauf autorisation expresse. Tout manquement a cette regle constitue un abus evident et expose son auteur au versement de dommages et interets. Tous droits de propriete industrielle reserves, notamment en matiere de brevets et de modesles.

Wiedergabe sowie Vervielfaltigung dieser Unterlagen, Verwertung und Mitteilung ihres Inhalts nicht gestattet, soweit nicht ausdrücklich ansonsten, Zuerkennung. Zuwiderhandlungen stellen einen offensichtlichen Missbrauch dar und verpflichten zu Schadensersatz. Alle Rechte fuer den Fall der Patenterteilung oder Gebrauchsmuster-Eintragung vorbehalten.

POS.	NAME	QUANTITY
1	SPRING	4

General Specification: JED-334-1, Size ISO 14405 LP		Copyright WABCO®		ProVia	
Further Technical Data: 340 319 005 2		Date	Signature		
Doc. Code: 014 Sheet: 1 To 3		2021-09-28	Sivoprosom	KIT: BRAKE PAD	
General Tolerances JED-261		2021-09-28	Manivanon		
Range of Nominal Dimensions (± mm)		Expert		Date of first issue: 2021-05-17	
Class 1)	≤ 50 > 50 ≤ 180 > 180 ≤ 400 > 400	Thomas Bilsing		Material No.	
Fine	0.5 1.0 1.5 2.0	Mass	Scale	340 319 005 2	
Medium	1.0 2.0 3.0 4.0	11.29 KG	1:1	Doc. Code Language Sheet	
Coarse	2.0 3.5 5.0 6.5	±3°	Size CAD System	005 EN 2/2	
Tapped Holes acc. -		A 2	CREO	ECN-No. Revision Techn. Resp. Replacement for	
1) Tolerance Class Applied Crossmarked		509293 - B 6928_AM			