

MEASURING PRINCIPLE: INDUCTIVE
 SUPPLY VOLTAGE: PULSE 8 ... 16 V DC
 CURRENT CONSUMPTION: MAX. 90 mA
 THERMAL RANGE OF APPLICATION UNDER NORMAL AMBIENT CONDITIONS: -40°C ... +80°C
 SHORT TIME HEAT RESISTANCE: 110°C FOR MAX. 1 h
 AMBIENT MEDIUM: AIR (WATER-, OIL AND DUST CONTAINING)
 DISTANCE SENSOR WITHOUT TEMPERATURE COMPENSATION
 CABLE BETWEEN SENSOR AND ELECTRONIC CONTROL UNIT (ECU) LENGTH: MAX. 15 m WIRE CROSS SECTION: ≥1 mm²
 TYPE OF PROTECTION ACC. TO ISO 20653 (COMPLETE DEVICE WITH INSTALLED PLUG): IP 6K9K
 DISTANCE SENSOR CAN ONLY BE OPERATED IN CONNECTION WITH AN APPROPRIATE ADAPTION CIRCUIT

- 1) PROVIA DEVICE NUMBER
- 2) MANUFACTURER NUMBER
- 3) WEEK OF MANUFACTURE / YEAR OF MANUFACTURE
- 4) EAC MARK
- 1)-4) LASER MARKING

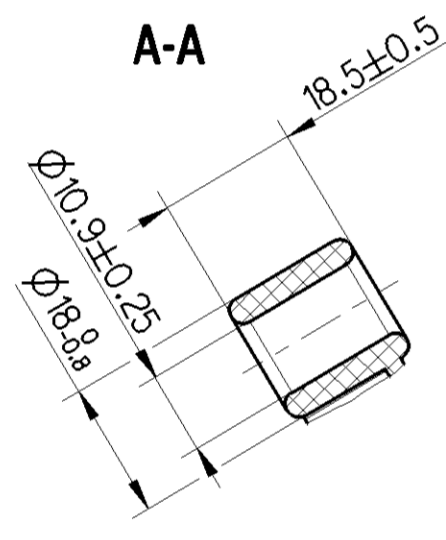
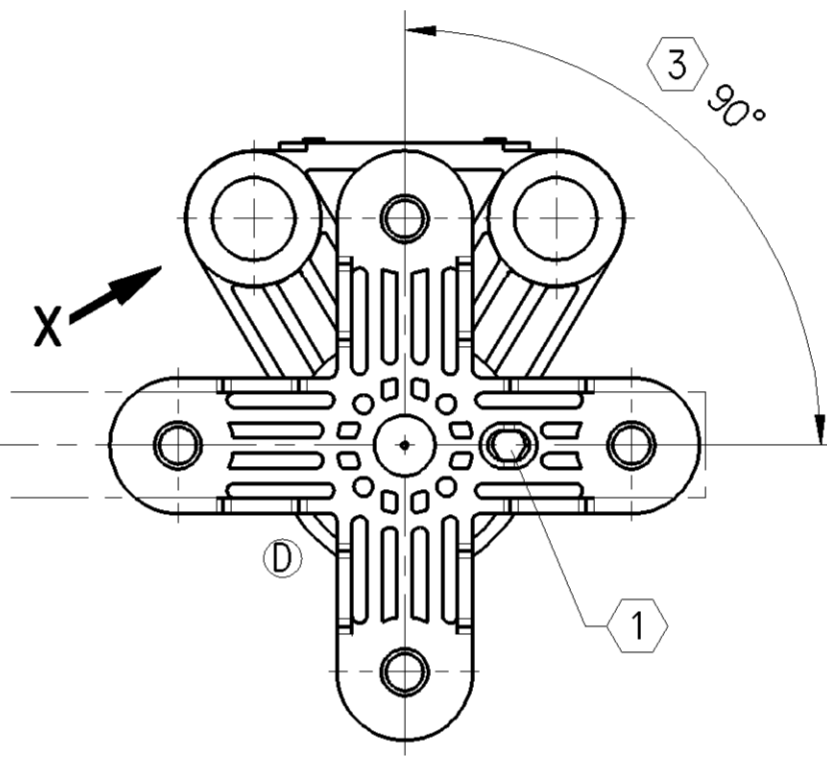
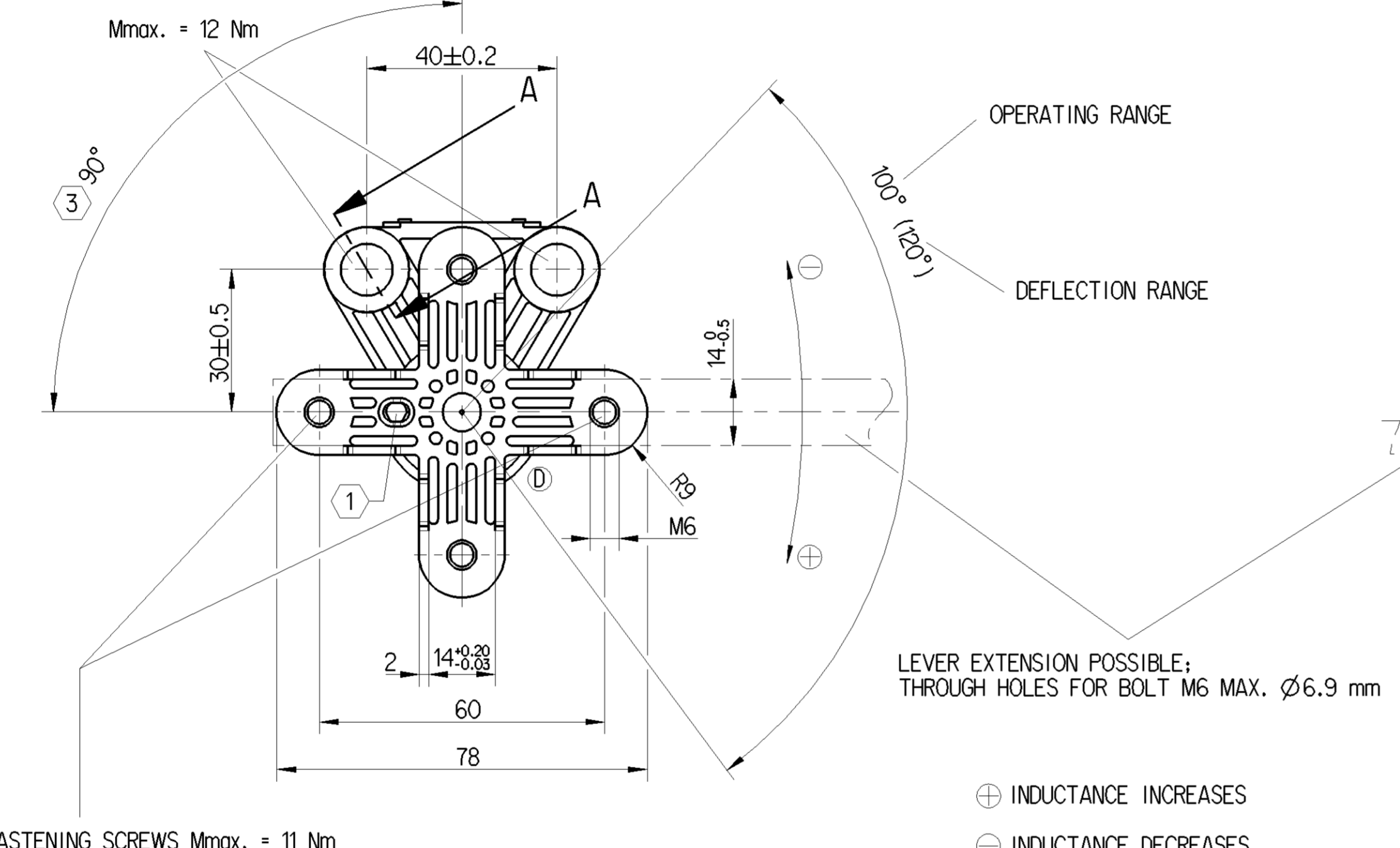

- 1) FIXING OF THE SENSOR IN CENTRAL POSITION BY MEANS OF MANDREL Ø4h8
- 2) Mmax.= 2 Nm (FOR 0.25% OF THE VIBRATIONS Mmax.= 8 Nm)
- 3) RELATIVE POSITION BETWEEN SENSOR FIXING AND FLANGE
- 4) OPERATING OF SENSOR IS POSSIBLE FROM FOUR SIDES, FOR THIS PURPOSE TURN LEVER

⊕ INDUCTANCE INCREASES
 ⊖ INDUCTANCE DECREASES

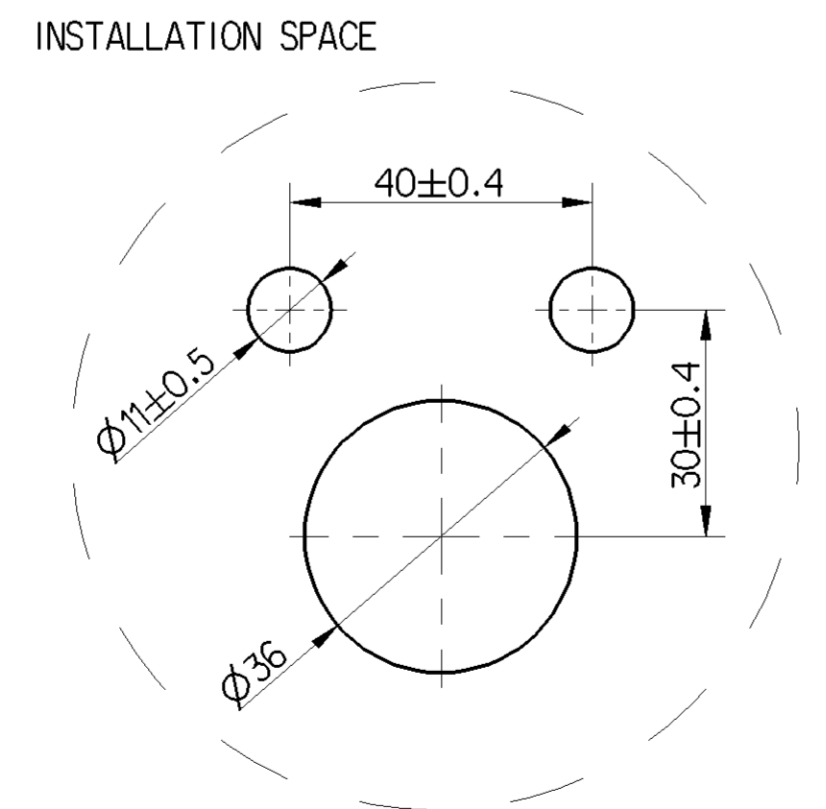

PLUG-IN CONNECTION ISO 15170 - A1-2.1-Sn/K2

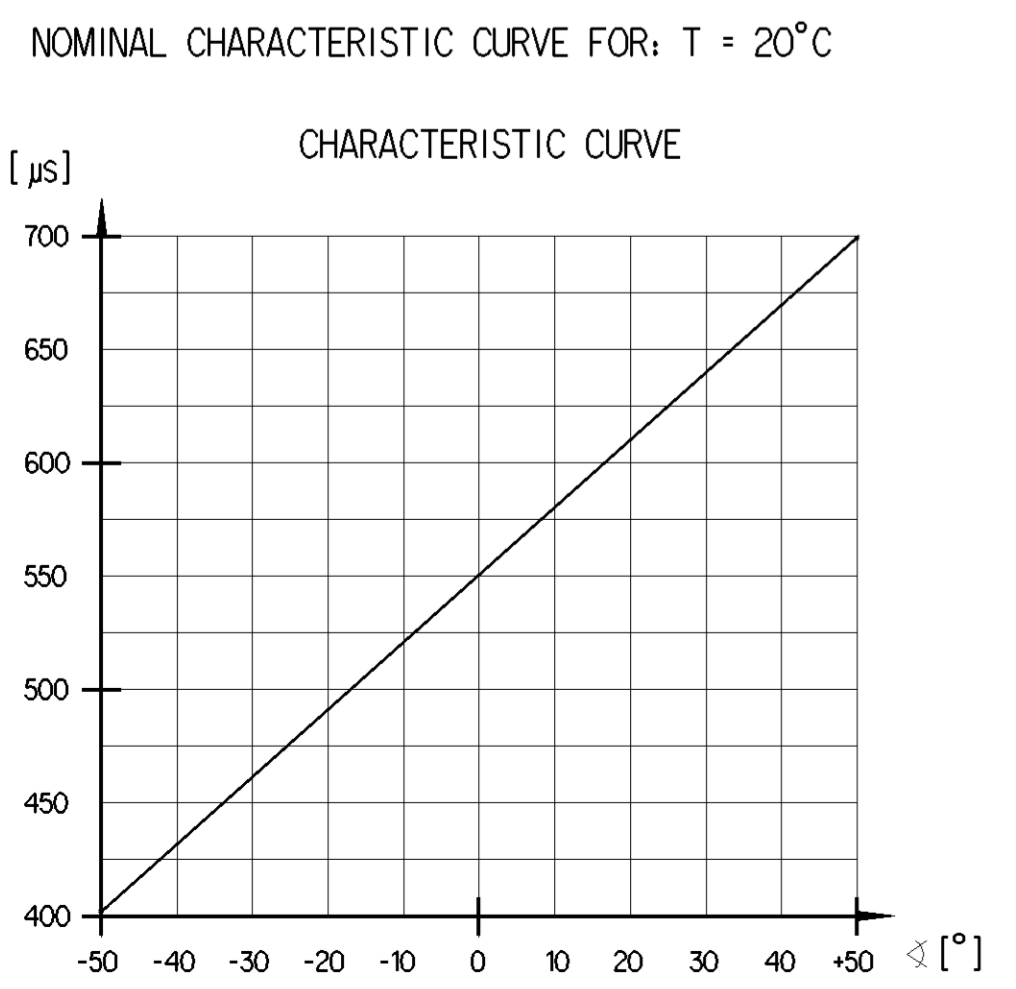
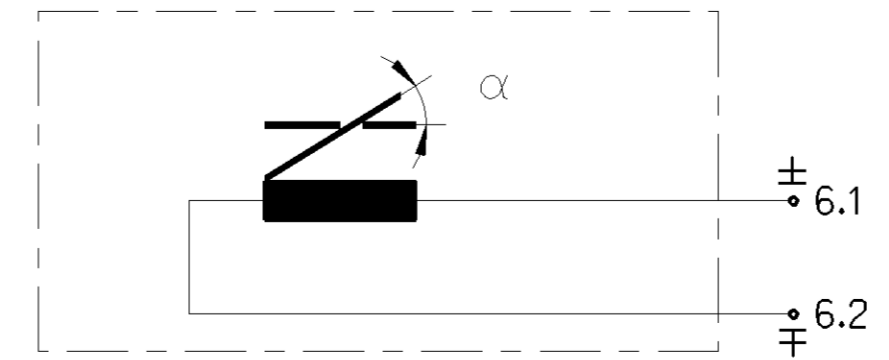
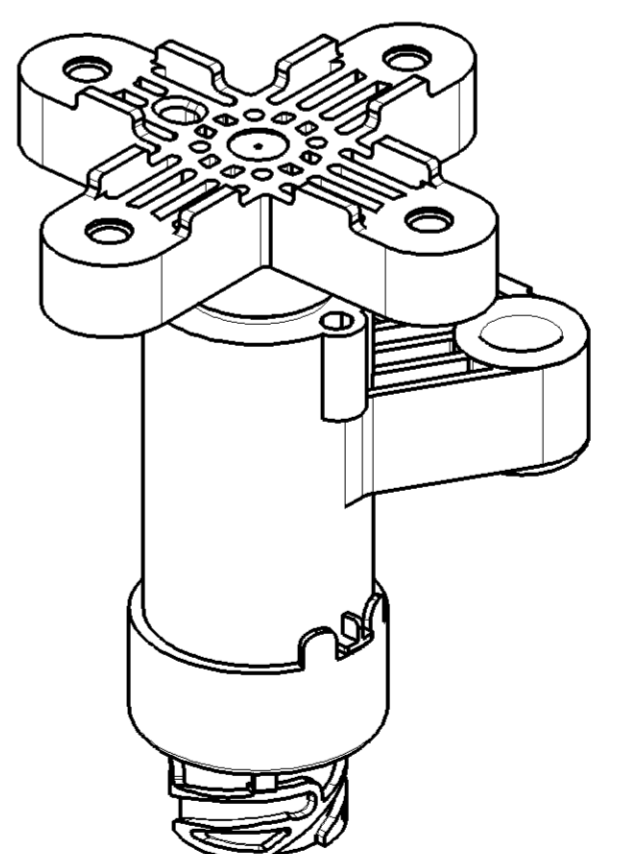
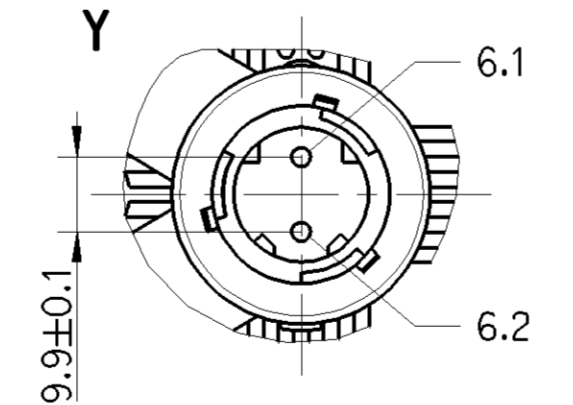

General Specifications: JED-334-1, Size ISO 14405 LP		Copyright WABCO®	
Further Technical Data: PRO4120300		Date: 2018-11-23	Signature: [Blank]
Doc. Code: 035	Sheet: 1 To 6	Brand: Kolkowski	Signature: [Blank]
General Tolerances JED-261		2018-11-23 Mzrcinkiewicz	
Range of Nominal Dimensions (± mm)			
Class	1) ≤ 50	> 50 < 180	> 180 < 400
Fine	0.5	1.0	1.5
Medium	X 1.0	2.0	3.0
Coarse	2.0	3.5	5.0
Tapped Holes acc. -		Expert: Kolkowski	
Mass	0.2 kg	Scale	1:1
Size	A 1	CAD System	CREO
Material No. PRO 412 033 0		Date of first issue: 2018-02-22	Doc. Code: 035
Revision: 2 x D		Techn. Resp.: 6660_AM	Language: EN
ECHA No.: 179377		Revision: 2 x D	Sheet: 1/1

Tutti i diritti sono riservati. È vietata espressamente la ristampa o l'uso non autorizzato senza permesso scritto dalla WABCO. Tutti i diritti sono riservati. È vietata espressamente la ristampa o l'uso non autorizzato senza permesso scritto dalla WABCO. All rights reserved. No part of this document may be reproduced or transmitted in any form or by any means, electronic or mechanical, including photocopying, recording, or by any information storage and retrieval system, without the prior written permission of WABCO. All rights reserved. No part of this document may be reproduced or transmitted in any form or by any means, electronic or mechanical, including photocopying, recording, or by any information storage and retrieval system, without the prior written permission of WABCO.