

SURFACE PROTECTION	
I	ZINC PLATED WITH CR6+ FREE
II	ELECTRO-COATING
III	DACROMET
IV	HARD POLYETHYLENE
V	STICKER

<D>	SAFETY CHARACTERISTICS	0
<D>	SIGNIFICANT CHARACTERISTICS	0
<D>	CUSTOMER INTERFACE	4

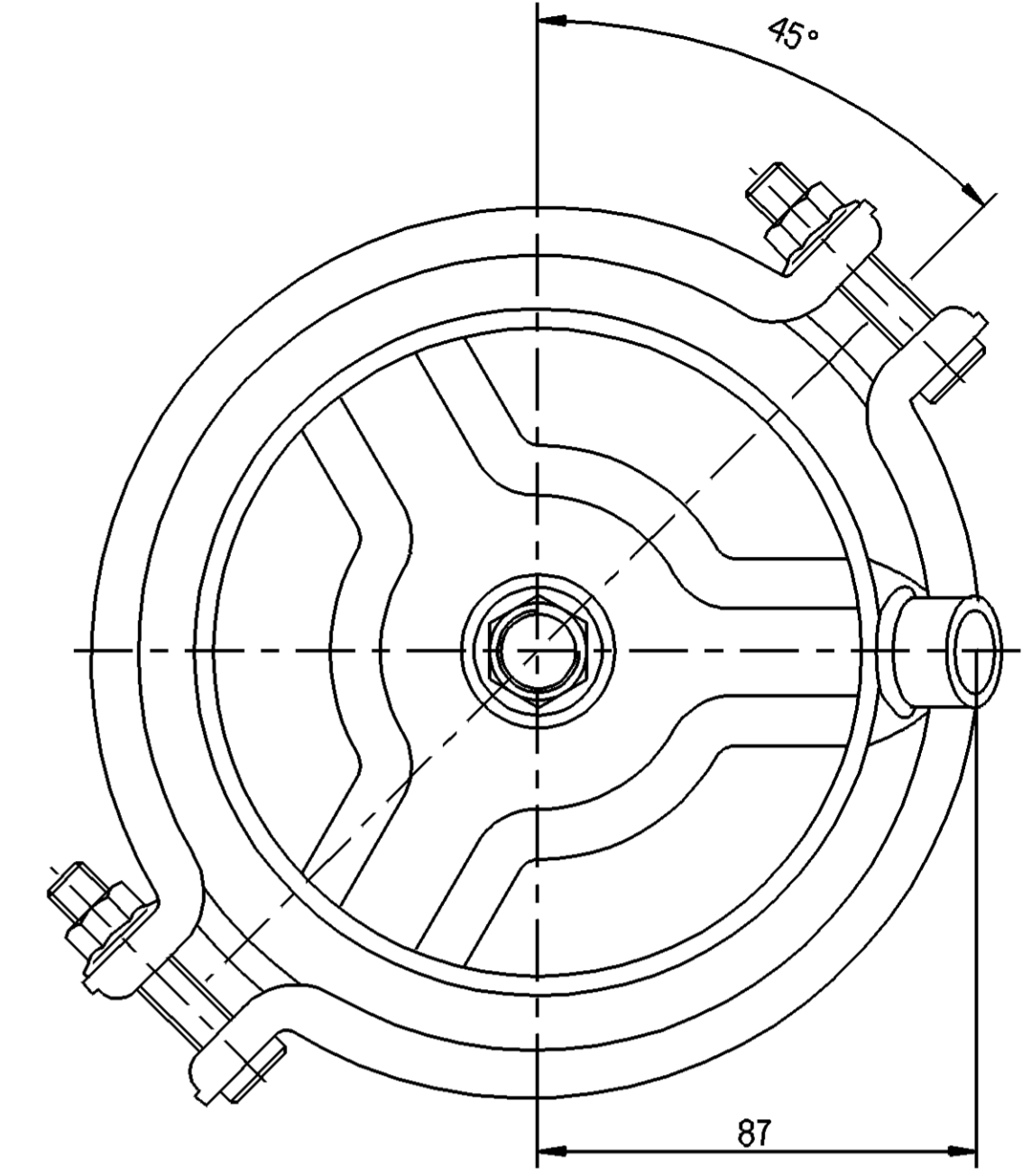

GRAPHS FOR INFORMATION ONLY

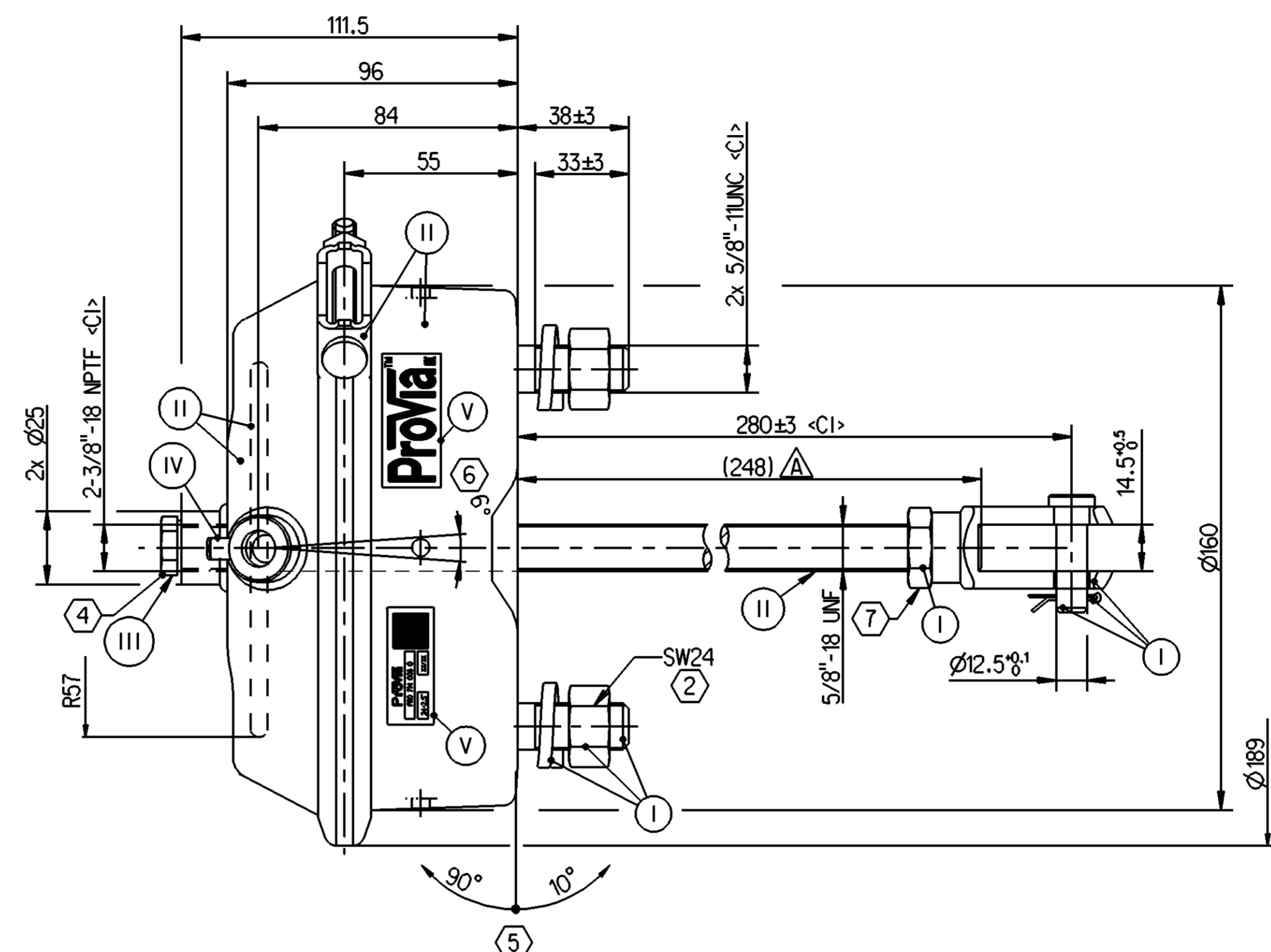
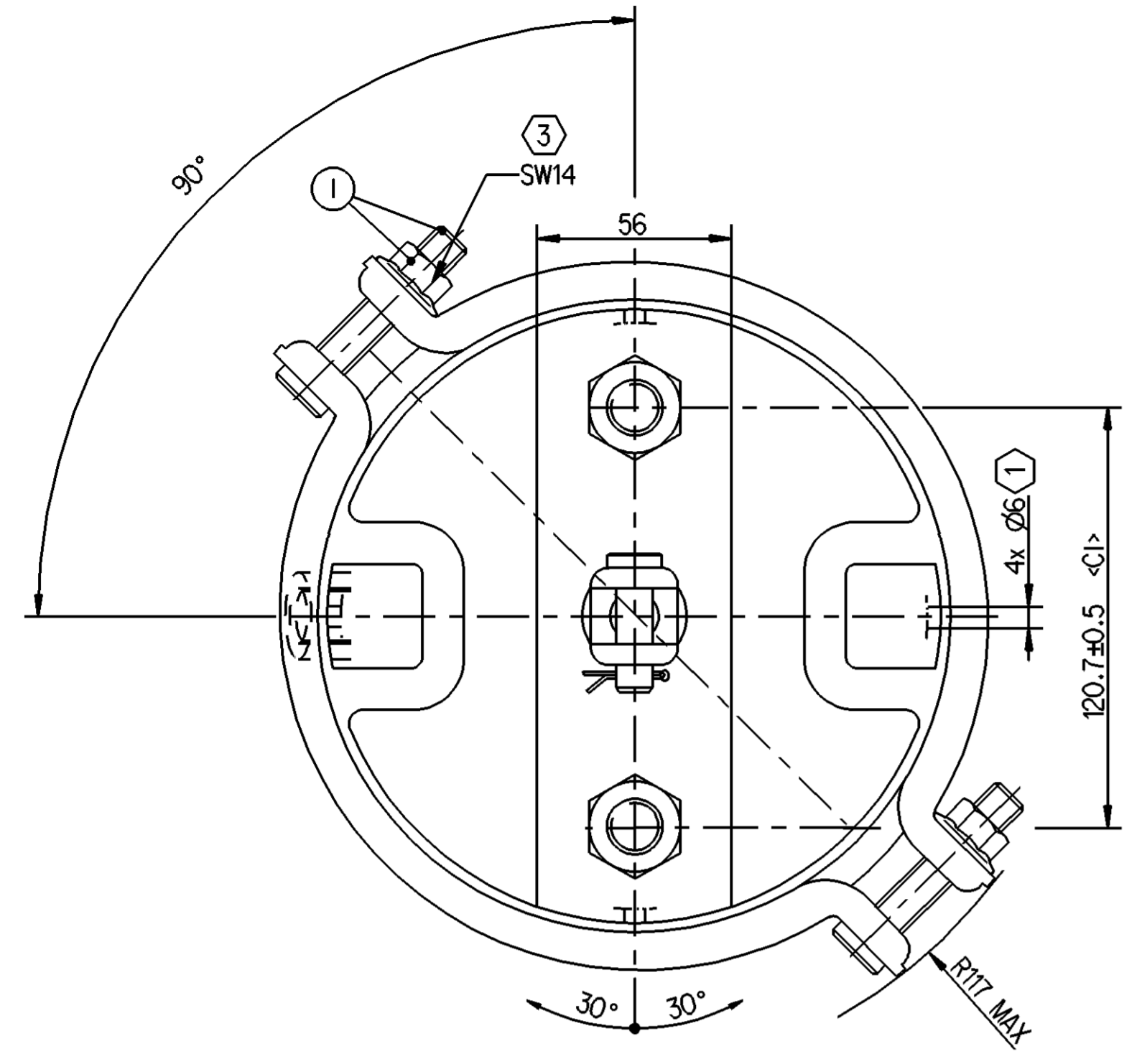
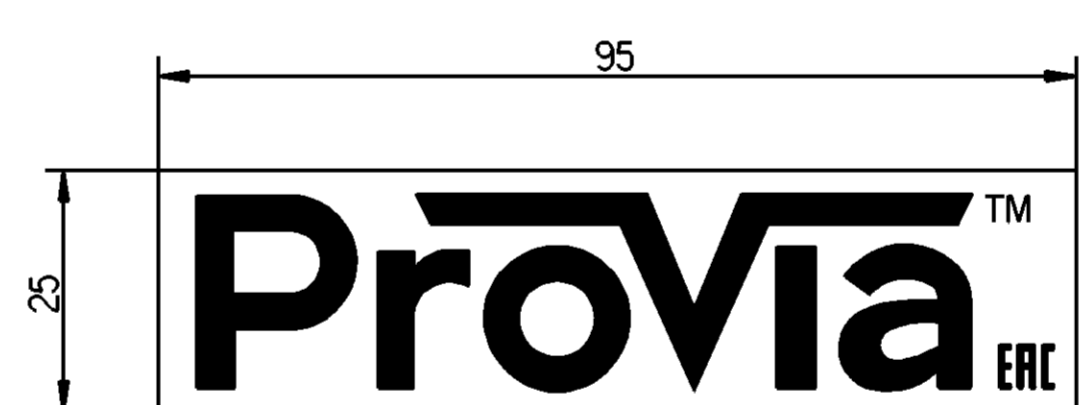
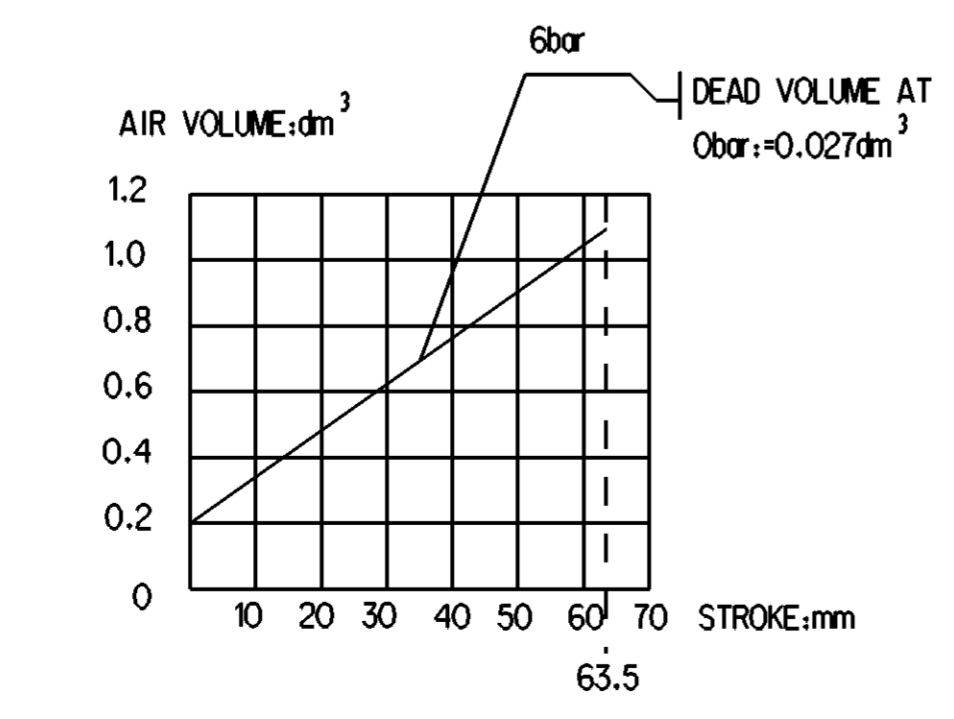
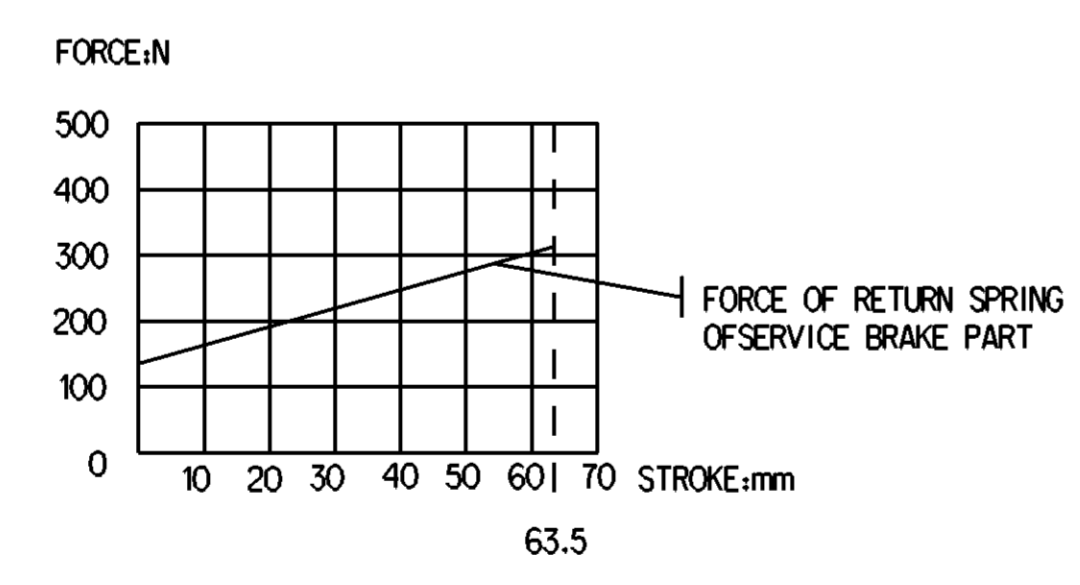
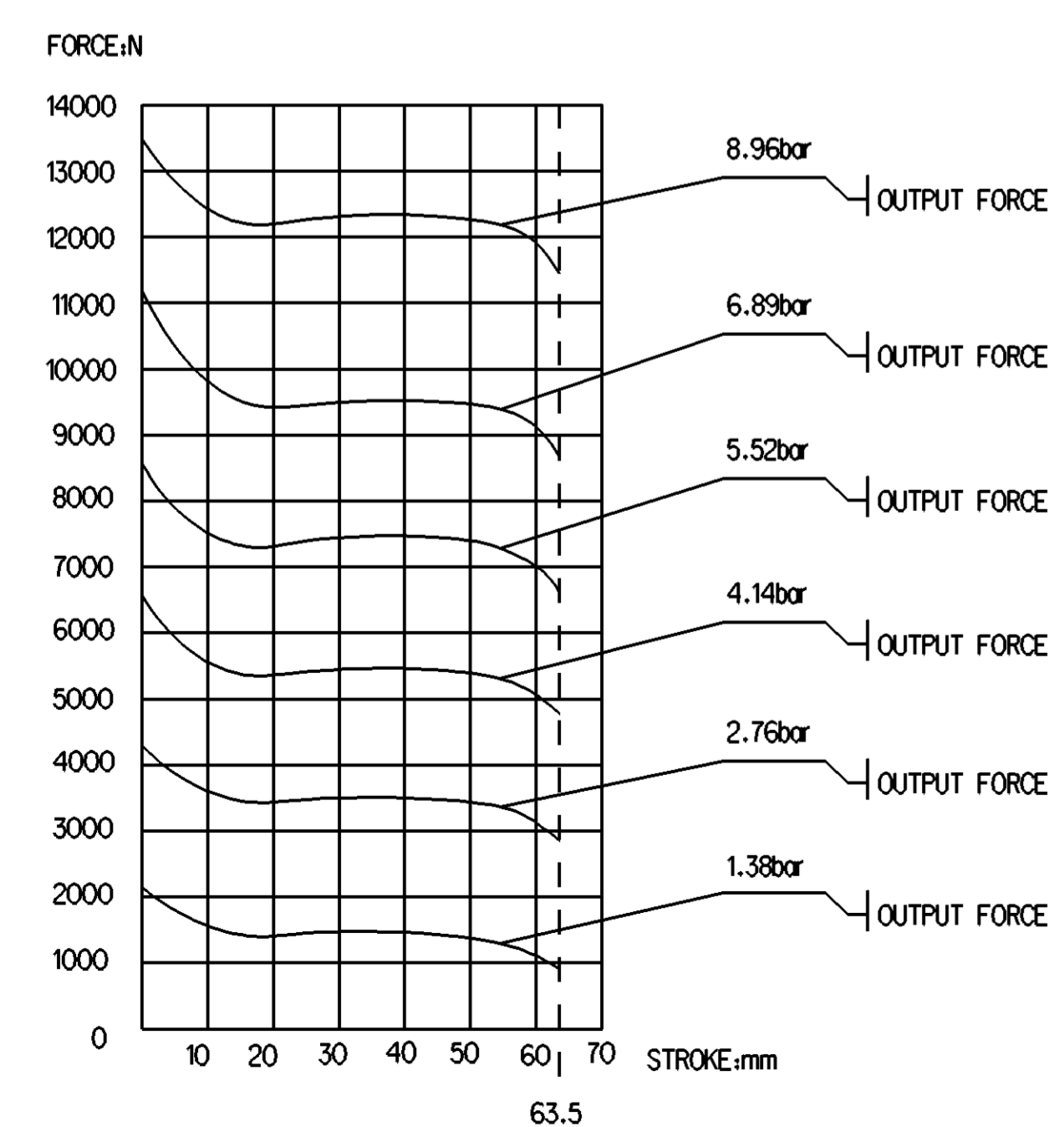

STICKER A
2:1

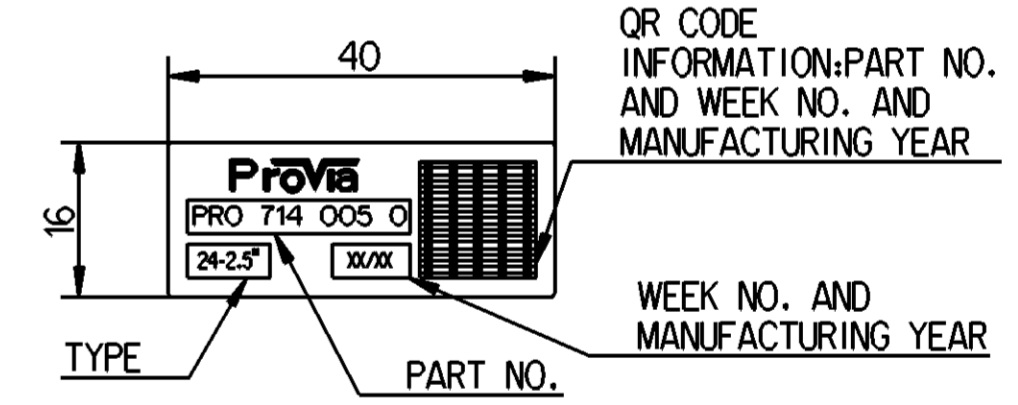

STICKER B

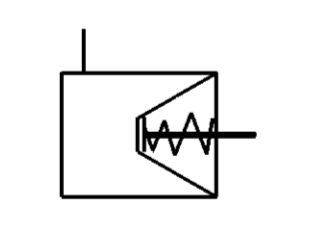

CIRCUIT DIAGRAM

- TECHNICAL REQUIREMENT:
1. STROKE: ≥ 63.5 mm (2.5")
 2. WORKING PRESSURE P_{MAX} : 8.5BAR
TEMPORARILY: 10BAR
 3. WORKING TEMPERATURE: -40°C....+80°C (-40°F.....+176°F)
 4. WORKING MEDIUM: AIR Δ

- ① OPEN BREATHER HOLE
- ② TORQUE: 220±20Nm
- ③ TORQUE: ≥ 25 Nm
- ④ TORQUE: 45±5Nm
- ⑤ ADMISSIBLE INSTALLATION POSITION
- ⑥ DEFLECTION: 6° MAX AT STROKE 0mm
- ⑦ TORQUE: 80±10Nm

General Specifications: ISO 8015, JED-334-1, Size ISO 14405 LP		Copyright ZF*	
Further Technical Data: PRO 714 016 0		Date	Signature
Doc. Code: 035	Sheet: 1 To 5	2023-05-05	Veritasolom
General Tolerances JED-261		2023-05-08	
Range of Nominal Dimensions (± mm)		Mannivan	
Class	1) ≤ 50	2) $50 > 180$	3) $180 \leq 400$
Fine	± 0.5	± 1	± 1.5
Medium	± 1	± 2	± 3
Coarse	± 2	± 3.5	± 5
Tapped Holes acc. JED-686		Dimensions in mm	
1) Tolerance Class Applied Crossmarked		Mass	Scale
		4.1 kg	NTS
		Size	CAD System
		A 1	CREO
		Material No.	
		PRO 714 005 0	
		Date of first issue:	2019-10-04
		Doc. Code	Language
		005	EN
		Revision	Techn. Resp.
		534015	4x A 5340_AM
		Replacement for	

Non e permesso copiare o riprodurre questo documento, ne utilizzare i contenuti o riprodurre immagini con o senza permesso. Toute reproduction ou utilisation de son contenu sans autorisation est interdite. Toute utilisation non autorisée de ce document est formellement interdite. Toute réimpression ou utilisation non autorisée sans la permission écrite de la ProVia est formellement interdite. Toute réimpression ou utilisation non autorisée sans la permission écrite de la ProVia est formellement interdite. Toute réimpression ou utilisation non autorisée sans la permission écrite de la ProVia est formellement interdite.