

SAFETY CHARACTERISTICS	0
SIGNIFICANT CHARACTERISTICS	0
CUSTOMER INTERFACE	0

MAXIMUM WORKING PRESSURE	8.5 bar
THERMAL RANGE OF APPLICATION	-40°C ...+80°C
TORQUE FOR CONNECTIONS	34Nm MAX.
1-1 SUPPLY	1-2 AIR RESERVOIR
21 RELAY EMERGENCY VALVE	22 SPRING BRAKE CYLINDER
3 AIR EXHAUST	MEDIUM: AIR
WORKING POSITION: UNIMPORTANT EXCEPT EXHAUST AT THE TOP	

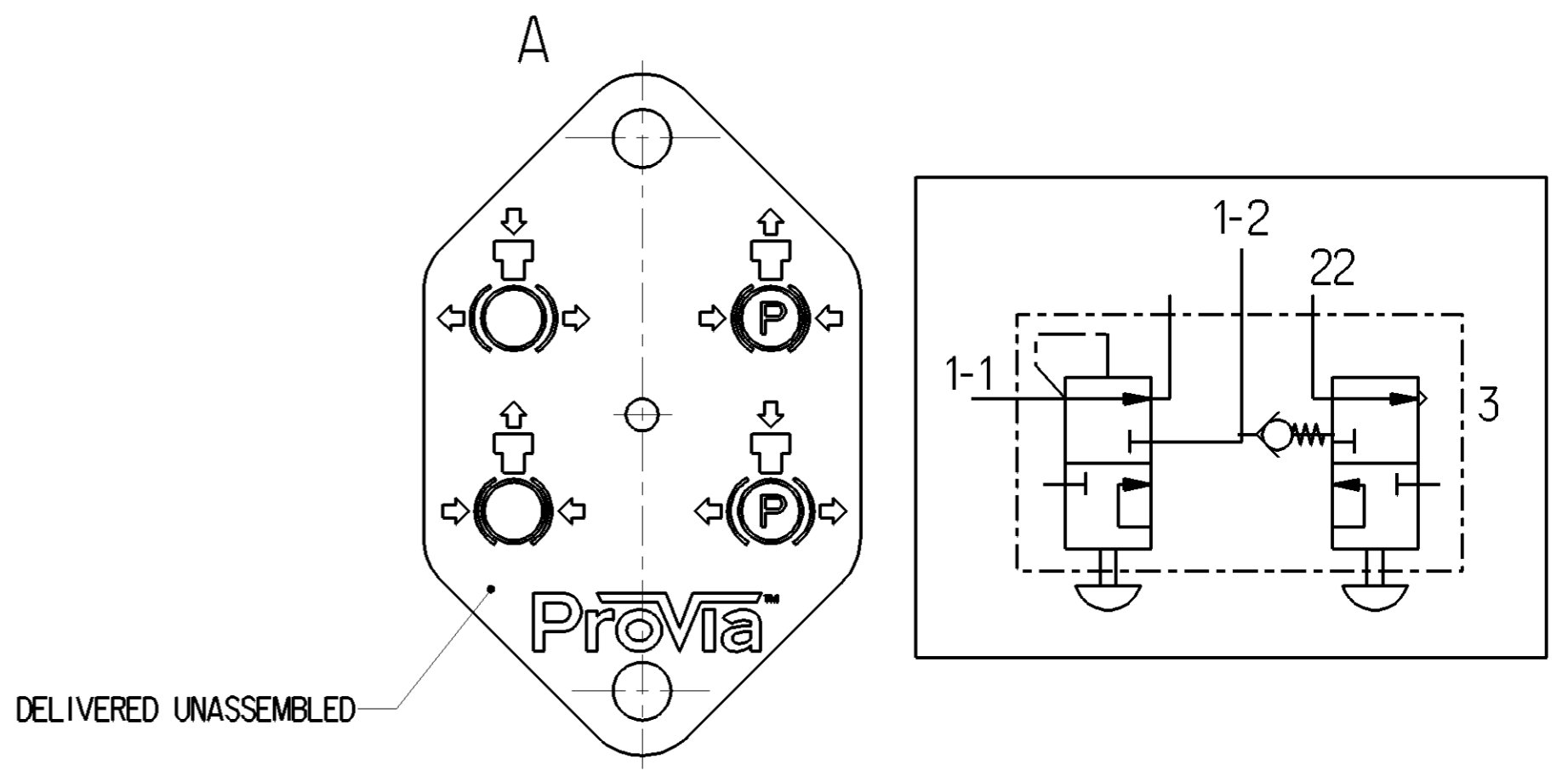
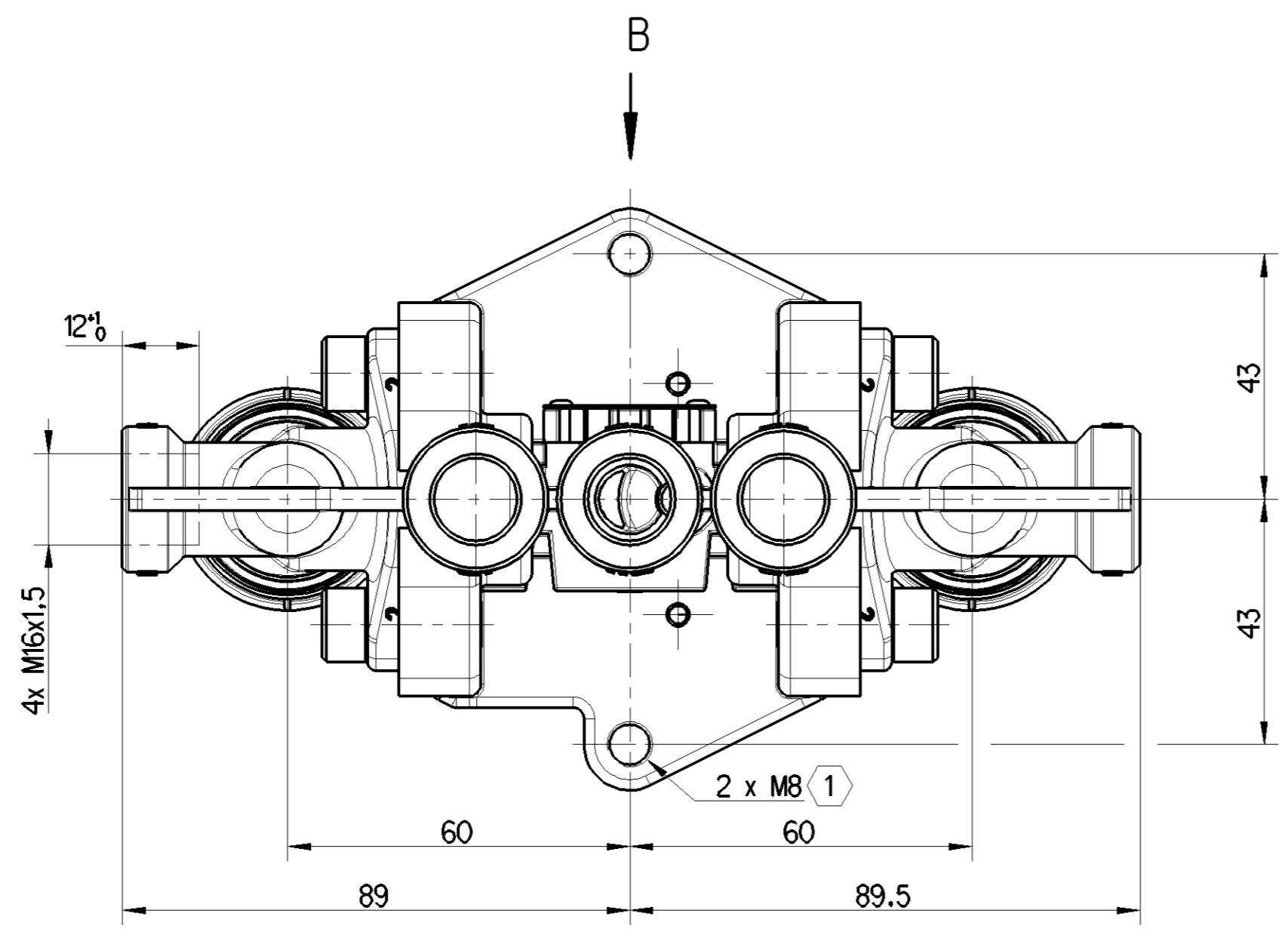
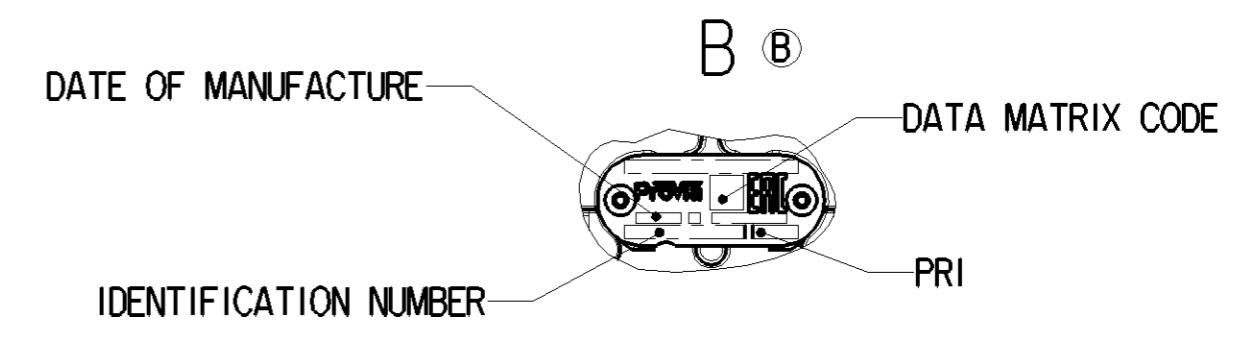
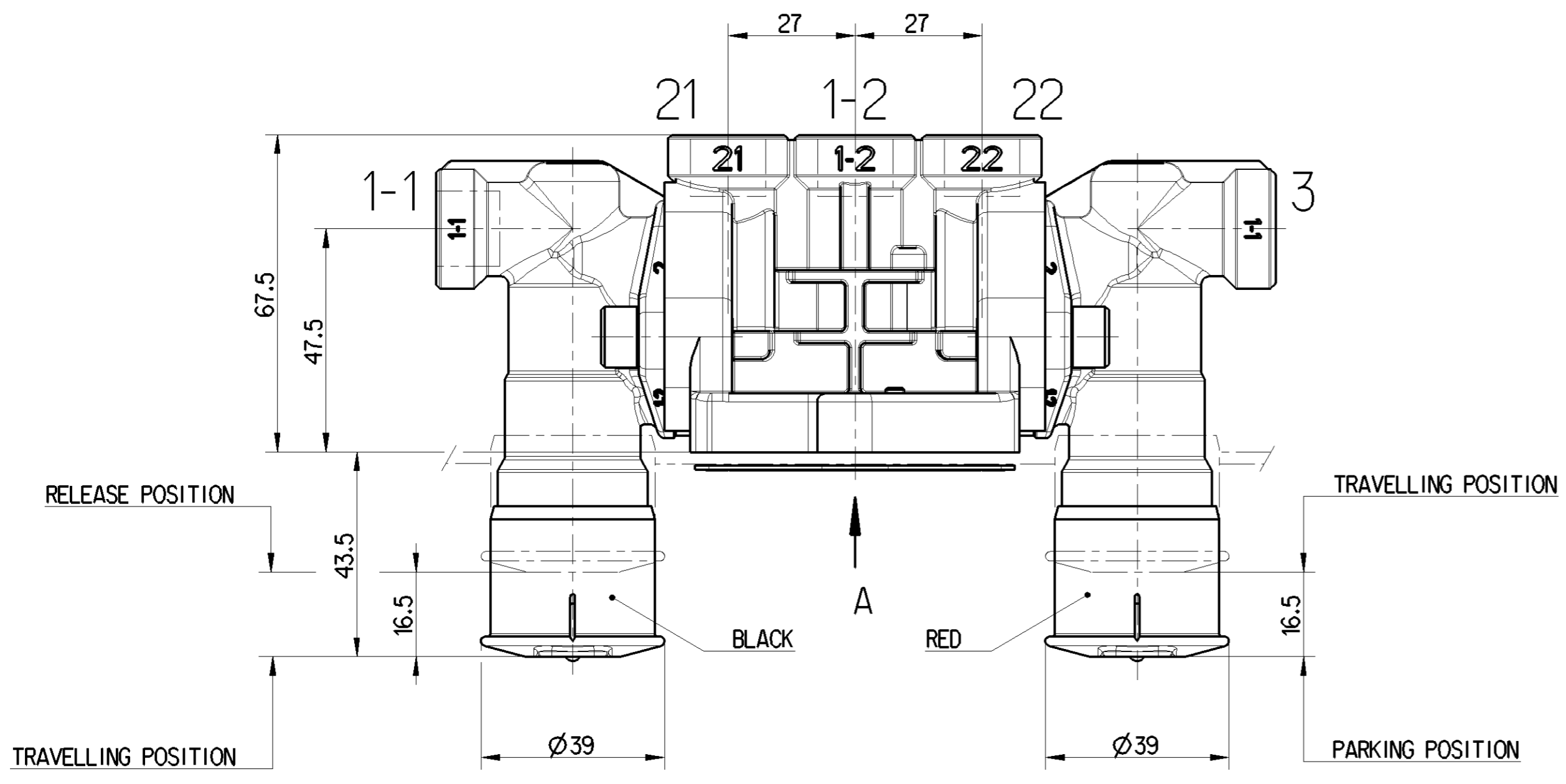

1 TORQUE 10Nm MAX.

General Specification: ISO 8015, JED-334-1, Size ISO 14405 LP		Copyright ZF®		ProVia	
Further Technical Data: PRO 527 005 0		Date	Signature	COVER PORT	
Doc. Code: 035	Sheet: 1 To 4	2023-04-24	Drawn: Murugan	Date of first issue: 2017-09-13	
General Tolerances JED-261		Checked	2023-04-24	Doc. Code Language Sheet	
Range of Nominal Dimensions (± mm)		Kolkowski		005 EN 1/1	
Class	1) ≤ 50 > 50 > 180 > 400 > 400	Dimensions in mm		Material No.	
Fine	±0.5 ±1 ±1.5 ±2	Mass	Scale	Date of first issue: 2017-09-13	
Medium	±1 ±2 ±3 ±4 ±3°	0.012 kg	1:1	Doc. Code Language Sheet	
Coarse	±2 ±3.5 ±5 ±6.5	Size	CAD System	PRO 527 005 0	
Tapped Holes acc. JED-152		A 2	CREO	ECN-No. Revision Techn. Resp.	
1) Tolerance Class Applied Crossmarked				513198 3 x B 5320_AM	

Non e' permesso cedere o terzi o riprodurre questo documento, ne utilizzare il contenuto o renderlo comunque noto a terzi senza autorizzazione esplicita. Ogni infrazione costituisce un evidente abuso e comportera il risarcimento dei danni subiti. E' fatta riserva di tutti i diritti derivanti da brevetti o marchi.

Toute communication ou reproduction de ce document, toute exploitation ou communication de son contenu sont interdites, sauf autorisation expresse. Tout manquement a cette regle constitue un abus evident et expose son auteur au versement de dommages et interets. Tous droits de propriete industrielle reserves, notamment en matiere de brevets et de marques.

Weitergabe sowie Vervielfaeltigung dieser Unterlagen, Verwertung und Mitteilung ihres Inhalts nicht gestattet, soweit nicht ausdrucklich zugestanden. Zuwiderhandlungen stellen einen offensichtlich missbrauch dar und verpflichten zu Schadenersatz. Alle Rechte fuer den Fall der Patenterteilung oder Gebrauchsmuster-Erteilung vorbehalten.

Toute communication ou reproduction de ce document, toute exploitation ou communication de son contenu sont interdites, sauf autorisation expresse. Tout manquement a cette regle constitue un abus evident et expose son auteur au versement de dommages et interets. Tous droits de propriete industrielle reserves, notamment en matiere de brevets et de marques.