

DELIVERED PRESSURE DIAGRAM

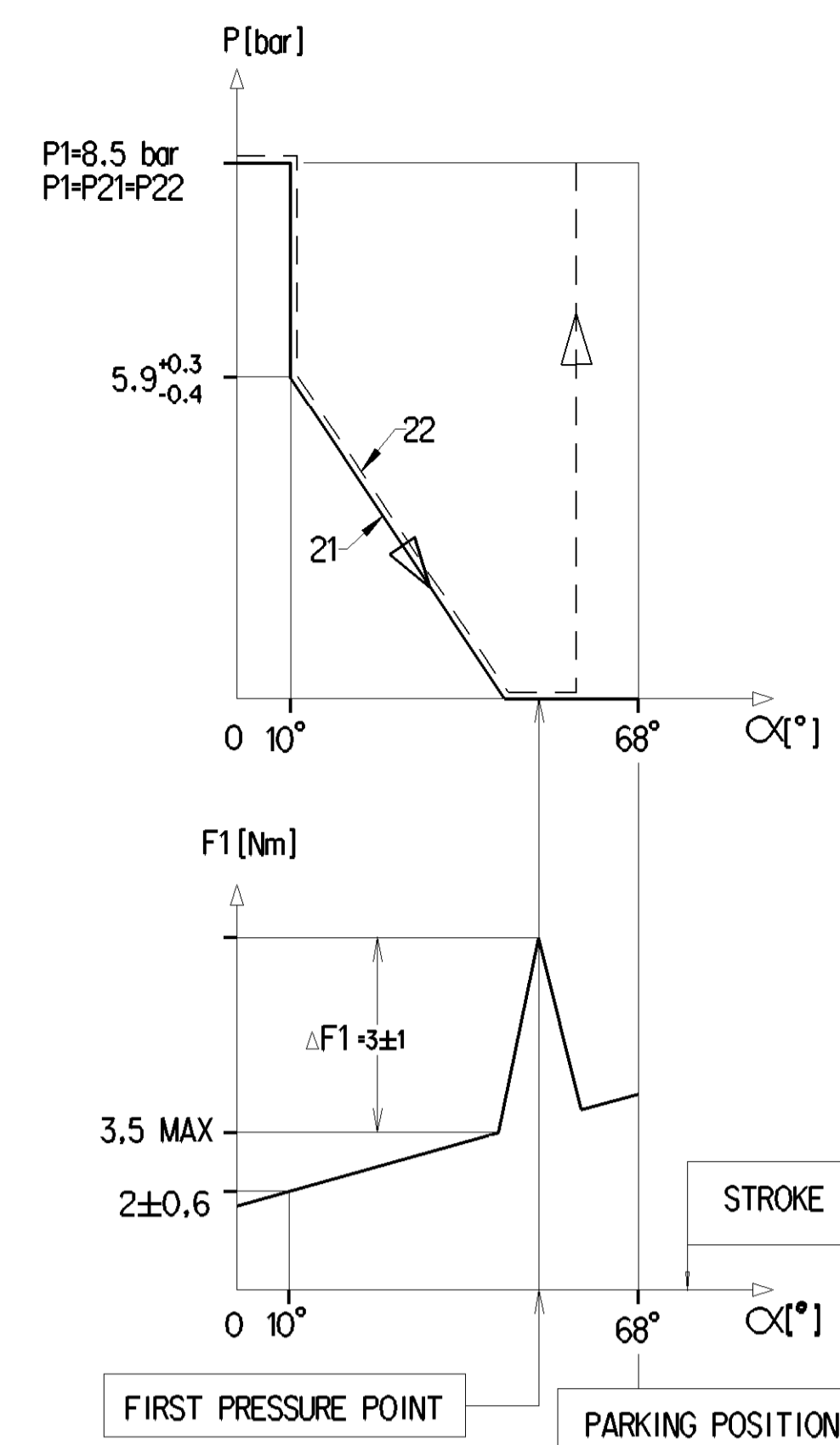

TESTING SCHEME

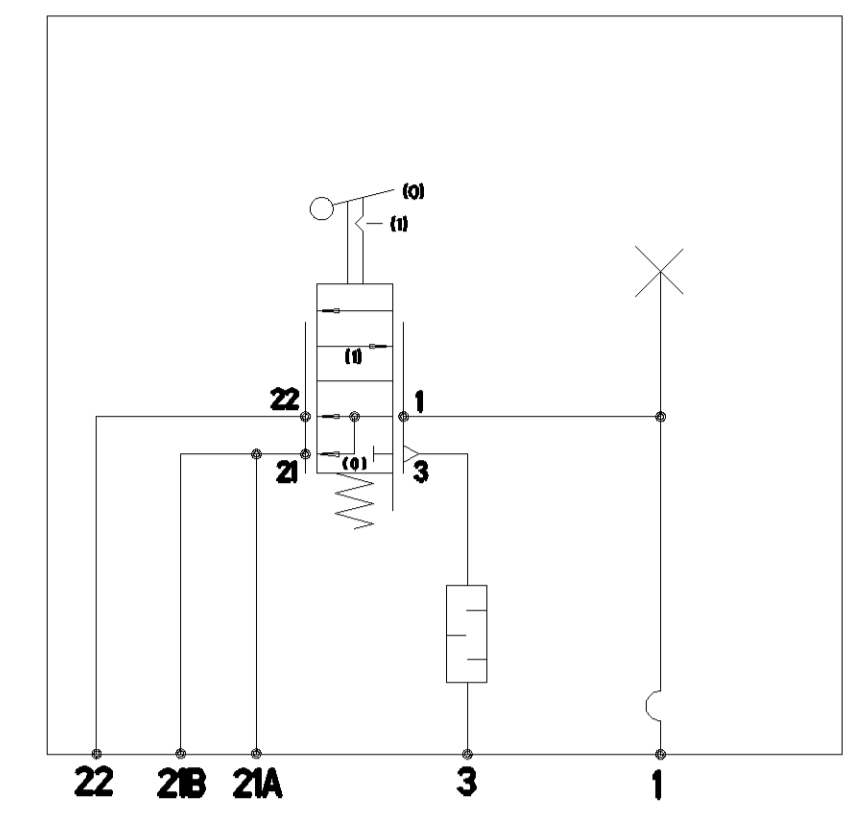

MARKING OF PORTS		GENERAL DATA	
1	SUPPLY	MEDIUM:	AIR
21A	SPRING BRAKE CYLINDER	THERMAL RANGE:	-40°C... +80°C
21B	PRESSURE SWITCH	OPERATING PRESSURE:	5.9 - 8.5 bar
22	TRAILER CONTROL VALVE	DELIVERY PRESSURE:	P1 = 13 bar MAX.
3	EXHAUST:	TORQUE:	9 Nm MAX.
		SILENCER	

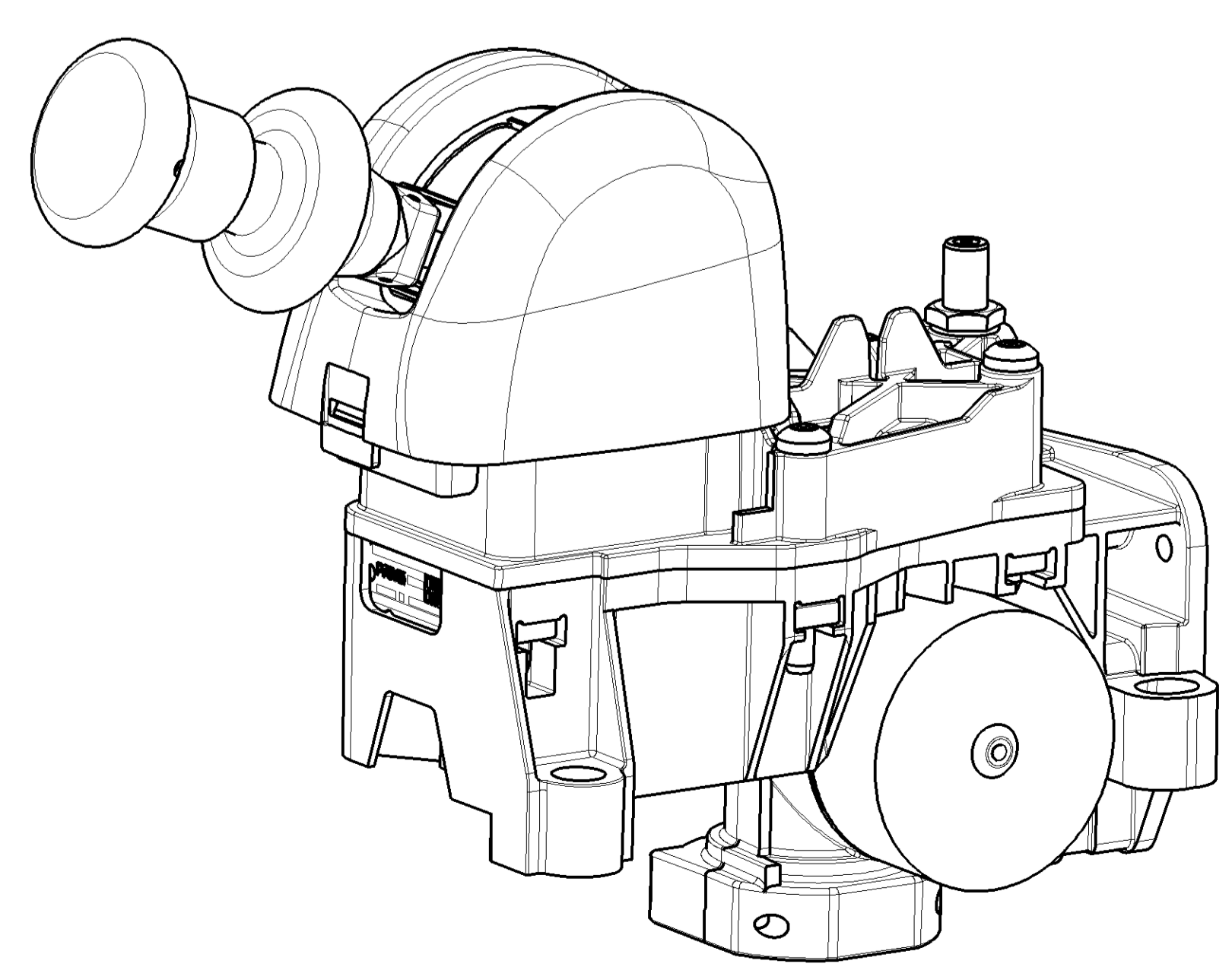
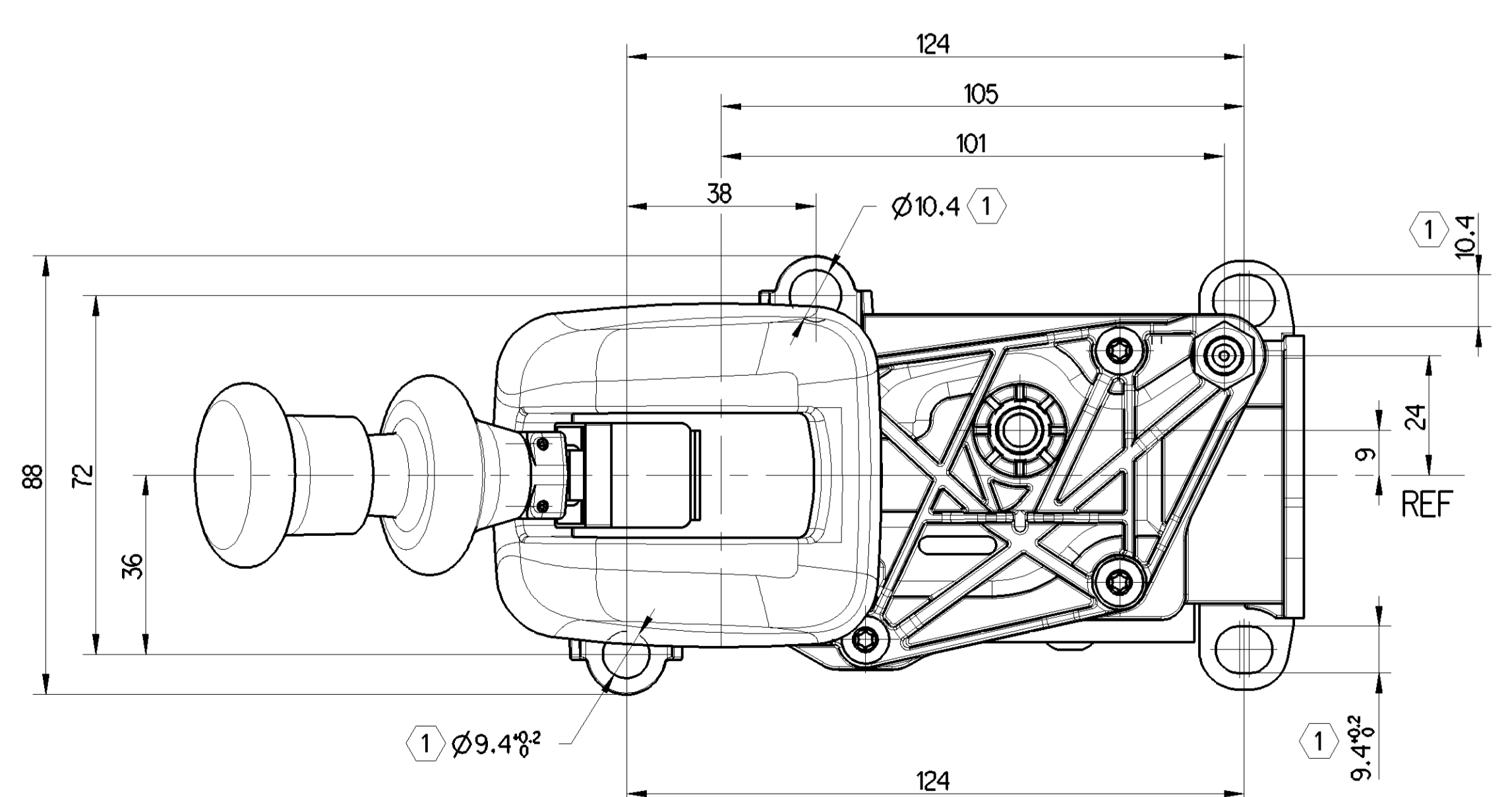
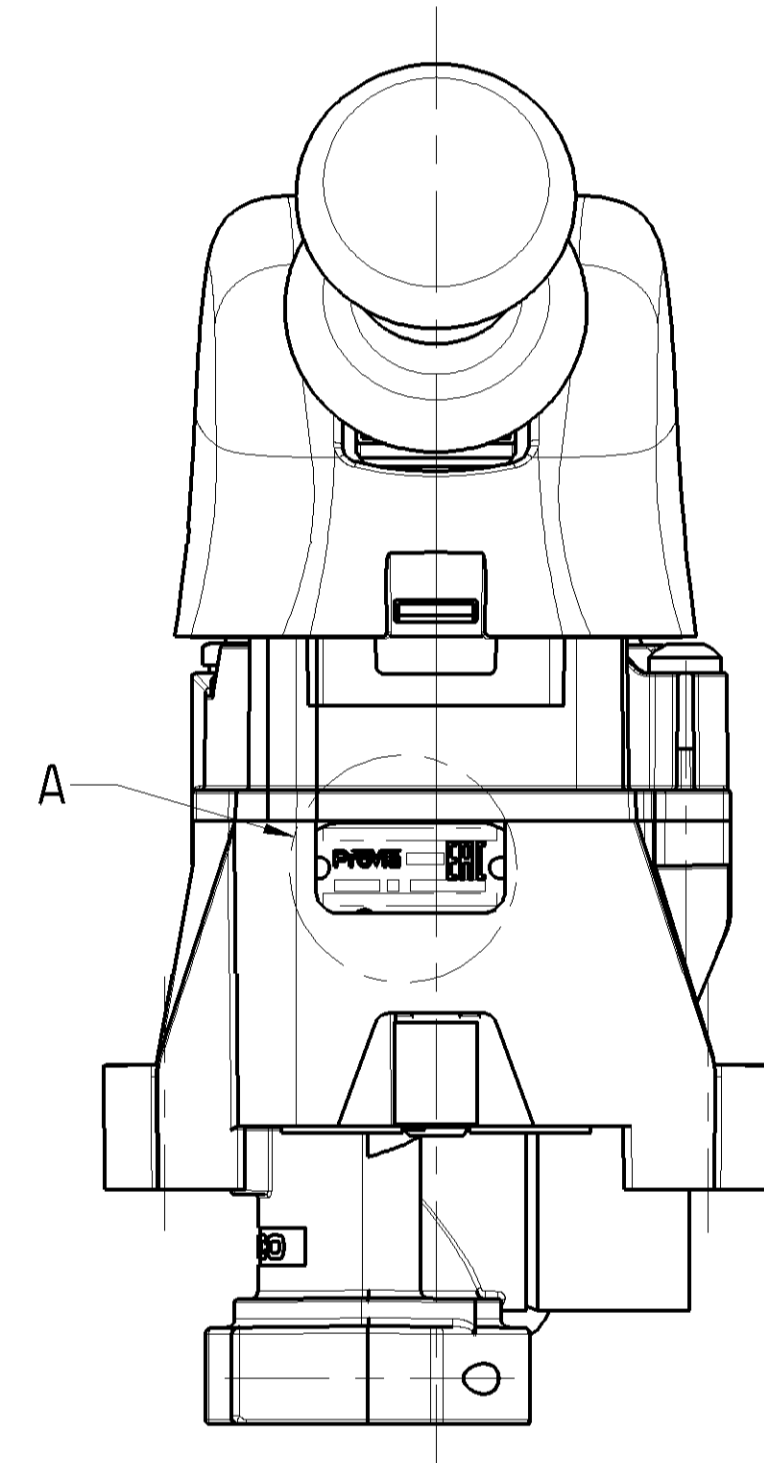
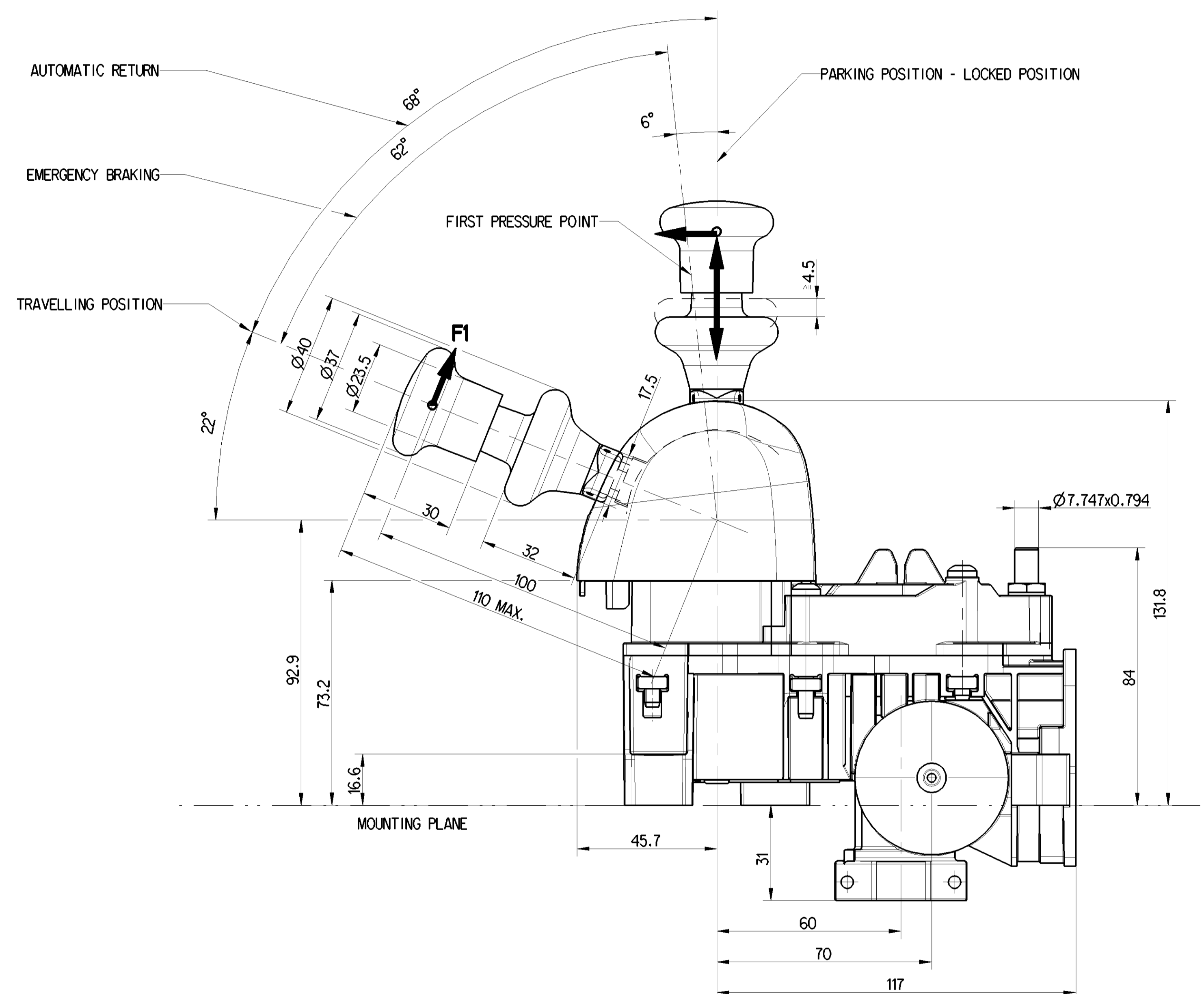

② THE LOCKING DEVICE MUST AUTOMATICALLY AND SAFELY LOCK THE HANDLE IN THE PARKING POSITION

General Specification: 4E5-334-1 - Size ISO 14405 LP		Copyright 2021		PROVIA	
Further Technical Data: Product Specification		Doc. Code: 035		HAND BRAKE UNIT	
Date: 2021-03-26		Version: 1 To 7		Author: Błoczek	
General Tolerances: ISO 2011		Date of first issue: 2018-07-12		Doc. Code: 005	
Range of Nominal Dimensions l (a mm)		2021-03-29		EN 1/1	
Class	l	Material No.	Revision	Order No.	Replacement for
1	50 - 180	PRO 645 010 0			
2	180 - 400				
3	400 - 600				
4	600 - 800				
5	800 - 1000				
6	1000 - 1200				
7	1200 - 1400				
8	1400 - 1600				
9	1600 - 1800				
10	1800 - 2000				
11	2000 - 2200				
12	2200 - 2400				
13	2400 - 2600				
14	2600 - 2800				
15	2800 - 3000				
16	3000 - 3200				
17	3200 - 3400				
18	3400 - 3600				
19	3600 - 3800				
20	3800 - 4000				
21	4000 - 4200				
22	4200 - 4400				
23	4400 - 4600				
24	4600 - 4800				