

PROVIA PART NUMBER	MASS M [kg]	NUMBER OF COILS N	THREAD O	WRENCH SIZE R	THREAD P	WRENCH SIZE S
PRO 711 056 0	0.489	21±1	M16x1.5 EXTERNAL / DESIGN I	22	M16x1.5 EXTERNAL / DESIGN I	22
PRO 711 057 0	0.489	21±1	M16x1.5 EXTERNAL / DESIGN I	22	M16x1.5 EXTERNAL / DESIGN I	22
PRO 711 058 0	0.517	21±1	M22x1.5 EXTERNAL / DESIGN I	27	M22x1.5 EXTERNAL / DESIGN I	27
PRO 711 059 0	0.517	21±1	M22x1.5 EXTERNAL / DESIGN I	27	M22x1.5 EXTERNAL / DESIGN I	27
PRO 711 060 0	0.491	21±1	M16x1.5 EXTERNAL / DESIGN I	22	M18x1.5 INTERNAL / DESIGN II	22
PRO 711 061 0	0.491	21±1	M16x1.5 EXTERNAL / DESIGN I	22	M18x1.5 INTERNAL / DESIGN II	22
PRO 711 062 0	0.493	21±1	M18x1.5 INTERNAL / DESIGN II	22	M18x1.5 INTERNAL / DESIGN II	22
PRO 711 063 0	0.493	21±1	M18x1.5 INTERNAL / DESIGN II	22	M18x1.5 INTERNAL / DESIGN II	22

PROVIA PART NUMBER	MATERIAL TABLE		
	MATERIAL SYMBOL	MATERIAL TYPE	SURFACE
PRO 711 056 0 PRO 711 058 0 PRO 711 060 0 PRO 711 062 0	1	MULTILAYER (PA12/PA6/PA12)	BLACK
	2	STEEL	MAT ZINC
	3	BRASS	-
	4	BRASS	-
	5	PLASTIC	RED
PRO 711 057 0 PRO 711 059 0 PRO 711 061 0 PRO 711 063 0	1	MULTILAYER (PA12/PA6/PA12)	BLACK
	2	STEEL	MAT ZINC
	3	BRASS	-
	4	BRASS	-
	5	PLASTIC	YELLOW

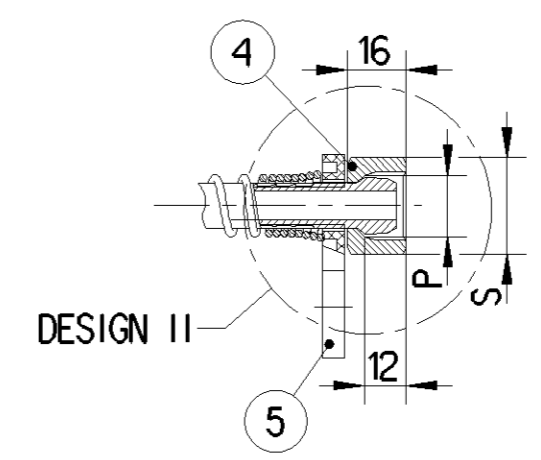
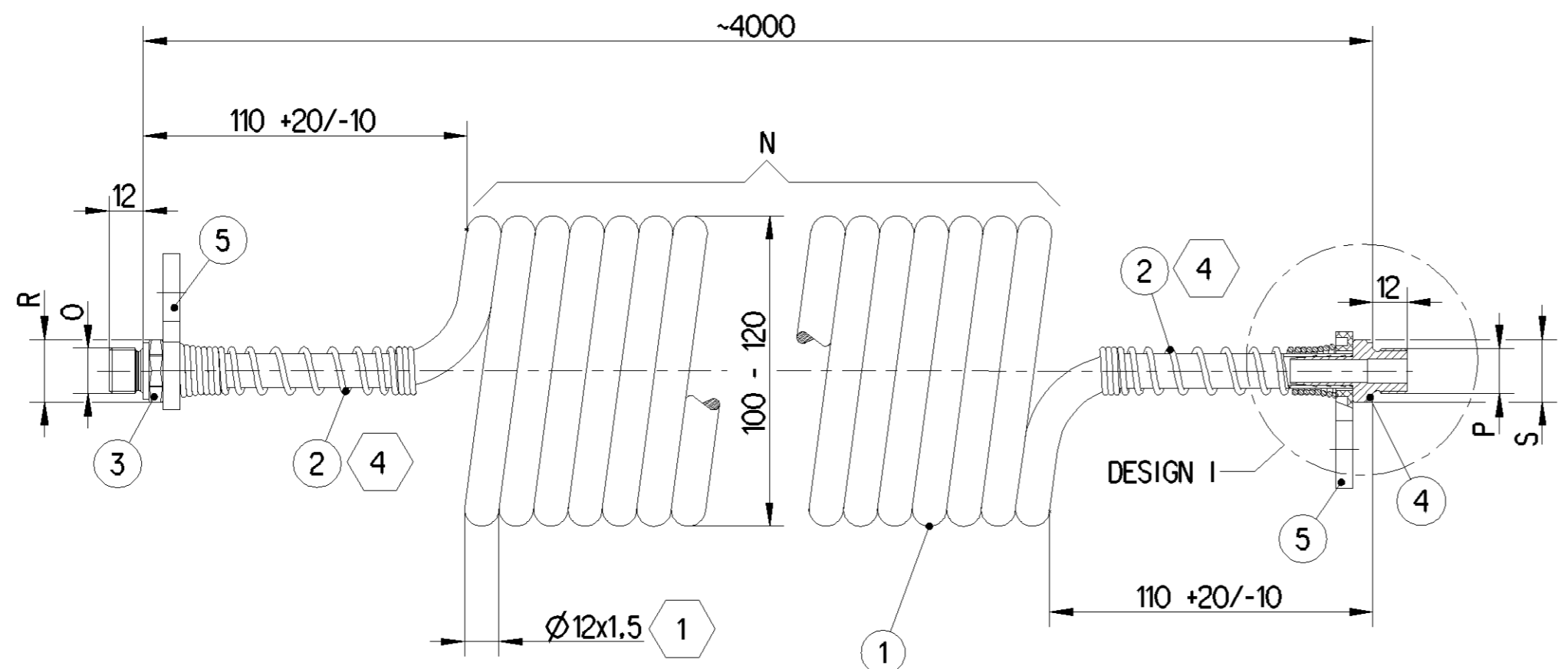

MEDIUM: AIR (ACC. TO JED-848)

PERMISSIBLE TEMPERATURE RANGE: -40 °C to +100 °C

PERMISSIBLE WORKING PRESSURE: MAX. 1000 kPa (10 bar)

MARKING: ProVia /PROVIA PART NUMBER/ - ISO 7375 / ISO 7628 - [A] - [B] - [C] - [D] - [E] - [F]

REQUIREMENT STANDARD: ISO 7375, TYPE 1
ISO 7628, CATEGORY 2

- A - CATEGORY OF MATERIAL STANDARD
- B - OUTSIDE DIAMETER TIMES WALL THICKNESS
- C - MATERIAL (ACCORDING TO ISO 1043-1)
- D - MANUFACTURER DESIGNATION
- E - DATE OF MANUFACTURE (ACCORDING TO SUPPLIER'S STANDARD)
- F - TRADEMARK: (HELVETICA FONT, MIN 5MM HEIGHT, CONTRASTING COLOR)

- 1 TUBE OVALITY: 12 +1/-2 mm
- 2 MANUFACTURER INTERNAL DEFINITION
- 3 MARKING REPEATS EACH 350MM
- 4 PART CORROSION PROTECTION LEVEL: 72 HOURS WITHOUT BASE METAL CORROSION NSS TEST ACC. TO ISO 9227

EXAMPLE: ProVia PRO 711 056 0 - ISO 7375 / ISO 7628 - CAT.2 - 12X1.5 - XXX.XX (PA12/PA6/PA12) - 123456 - 4115 - 15 - 098 - 15:08:26

ENGINEERING RELATED AGREEMENTS WITH SUPPLIER HAVE TO BE MENTIONED IN THE "RELEASE OF SUPPLIER"

GENERAL SPECIFICATION: ISO 7375; ISO 7628; ISO 1043-1; JED-367; JED-622; JED-762

General Specification: JED-334-1, Size ISO 14405 LP		Copyright WABCO®			
Further Technical Data:		Date	Signature		
Doc. Code:	Sheet:	To	Drawn	Coiled Tube	
General Tolerances JED-261			2018-04-06		
Range of Nominal Dimensions (± mm)			Checked		
Class 1)	≤ 50	> 50 ≤ 180	2018-04-09		
		> 180 ≤ 400	Expert	Date of first issue: 2015-06-25 Doc.Code Language Sheet 053 EN 1/1	
		> 400	Pawłowski		
Fine	0.5	1.0	1.5	2.0	Mass Scale kg NTS Size CAD System A 2 CREO
Medium	1.0	2.0	3.0	4.0	
Coarse	2.0	3.5	5.0	6.5	Material No. PRO 711 069 0 ECN-No. Revision Techn. Resp. 176966 1 x D 5690_AM
Tapped Holes acc. -				Date of first issue: 2015-06-25 Doc.Code Language Sheet 053 EN 1/1	
1) Tolerance Class Applied Crossmarked				Replacement for -	

Non e permesso copiare, o terzi o riprodurre questo documento, ne utilizzare il contenuto o renderlo comunque noto a terzi senza autorizzazione esplicita. Ogni infrazione costituisce un evidente abuso e comporterà il risarcimento dei danni subiti. E' fatta riserva di tutti i diritti derivanti da brevetti o modelli.
 Toute communication ou reproduction de ce document, toute exploitation ou communication de son contenu sont interdites, sauf autorisation expresse. Tout manquement a cette regle constitue un abus evident et expose son auteur au versement de dommages et interets. Tous droits de proprieete industrielle reserves, notamment en matiere de brevets et de modesles.
 Weitergabe sowie Vervielfältigung dieses Urteiles, Verwertung und Mitteilung desselben ist nicht gestattet, es sei denn mit ausdrücklicher Zustimmung des Verfassers. Alle Rechte sind vorbehalten.
 All rights reserved in the event of the grant of patent or registration of a utility model or design. This document is the subject of copyright.