

EXTERNAL SURFACE	
I	ZINC PLATED WITH CR6+ FREE
II	ELECTRO-COATING
III	DACROMET
IV	HARD POLYETHYLENE
V	RUBBER
VI	STICKER

<1>	SAFETY CHARACTERISTICS	0
<2>	SIGNIFICANT CHARACTERISTICS	0
<C1>	CUSTOMER INTERFACE	4

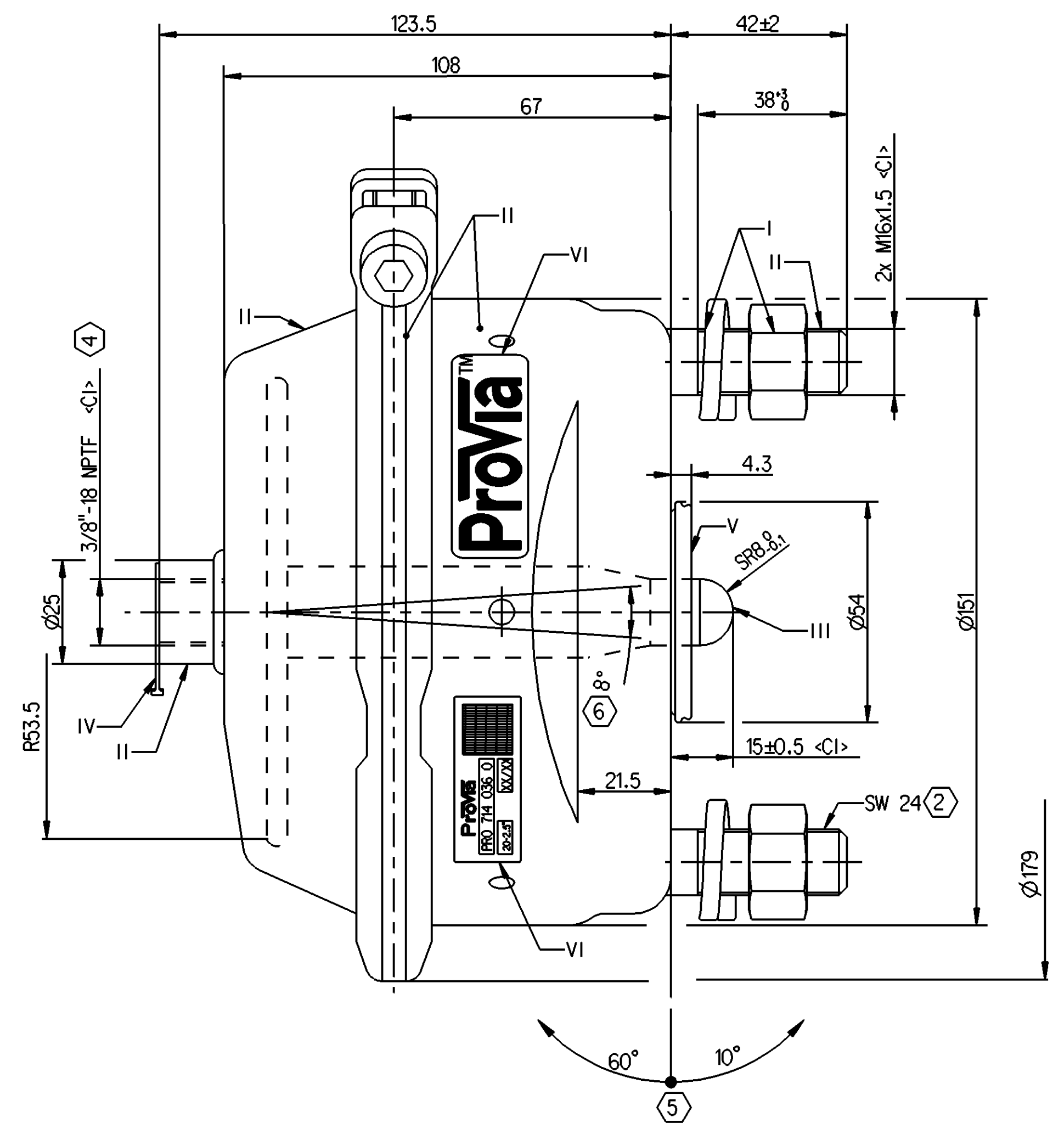
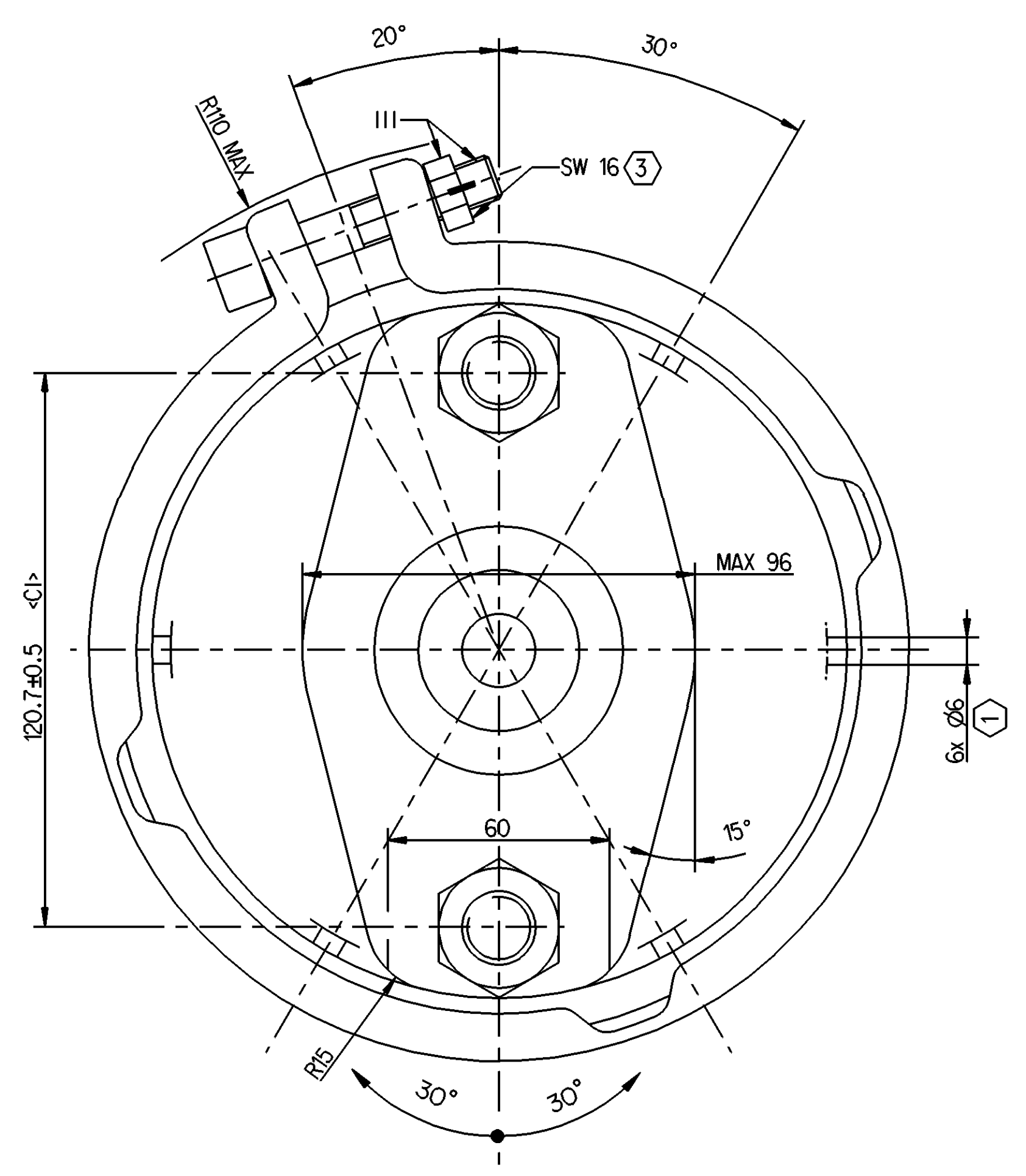

- TECHNICAL REQUIREMENT:
1. STROKE: ≥ 63.5 mm
 2. WORKING PRESSURE :
Pmax : 10.2 Bar, TEMPORARILY 13 Bar
 3. WORKING TEMPERATURE: $-40^{\circ}\text{C} \dots +80^{\circ}\text{C}$
 4. WORKING MEDIUM: AIR
 5. THIS PRODUCT MEETS THE REQUIREMENT OF QC/T 790 STANDARD

- ① OPEN BREATHER HOLE
- ② TORQUE: 220 ± 20 Nm
- ③ TORQUE: $35-40$ Nm
- ④ TORQUE: 45 ± 5 Nm
- ⑤ ADMISSIBLE INSTALLATION POSITION
- ⑥ DEFLECTION: 8° MAX AT STROKE 0mm

GRAPHS FOR INFORMATION ONLY

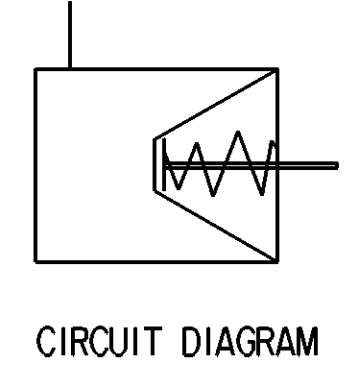
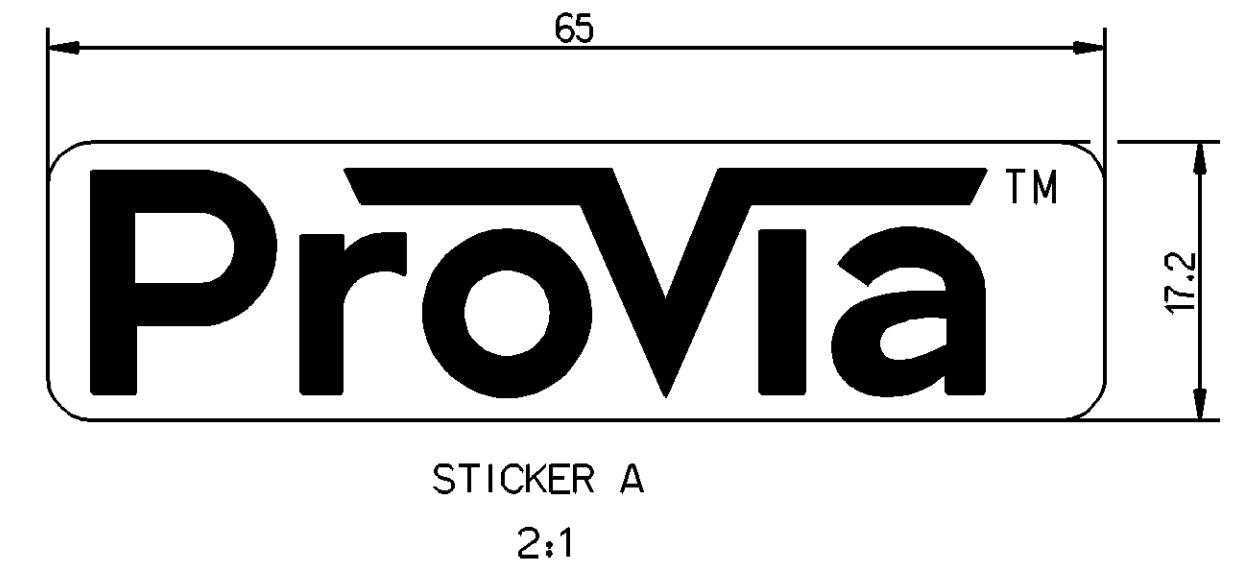
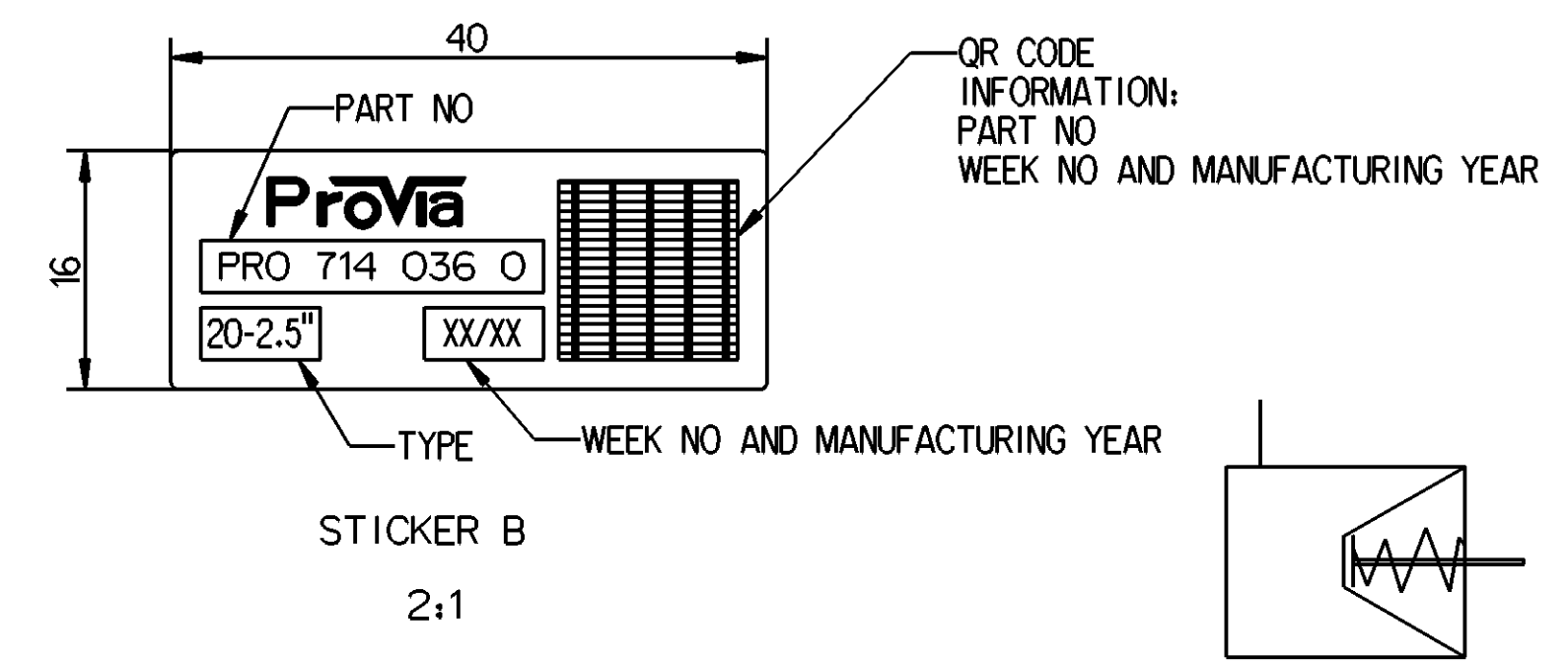
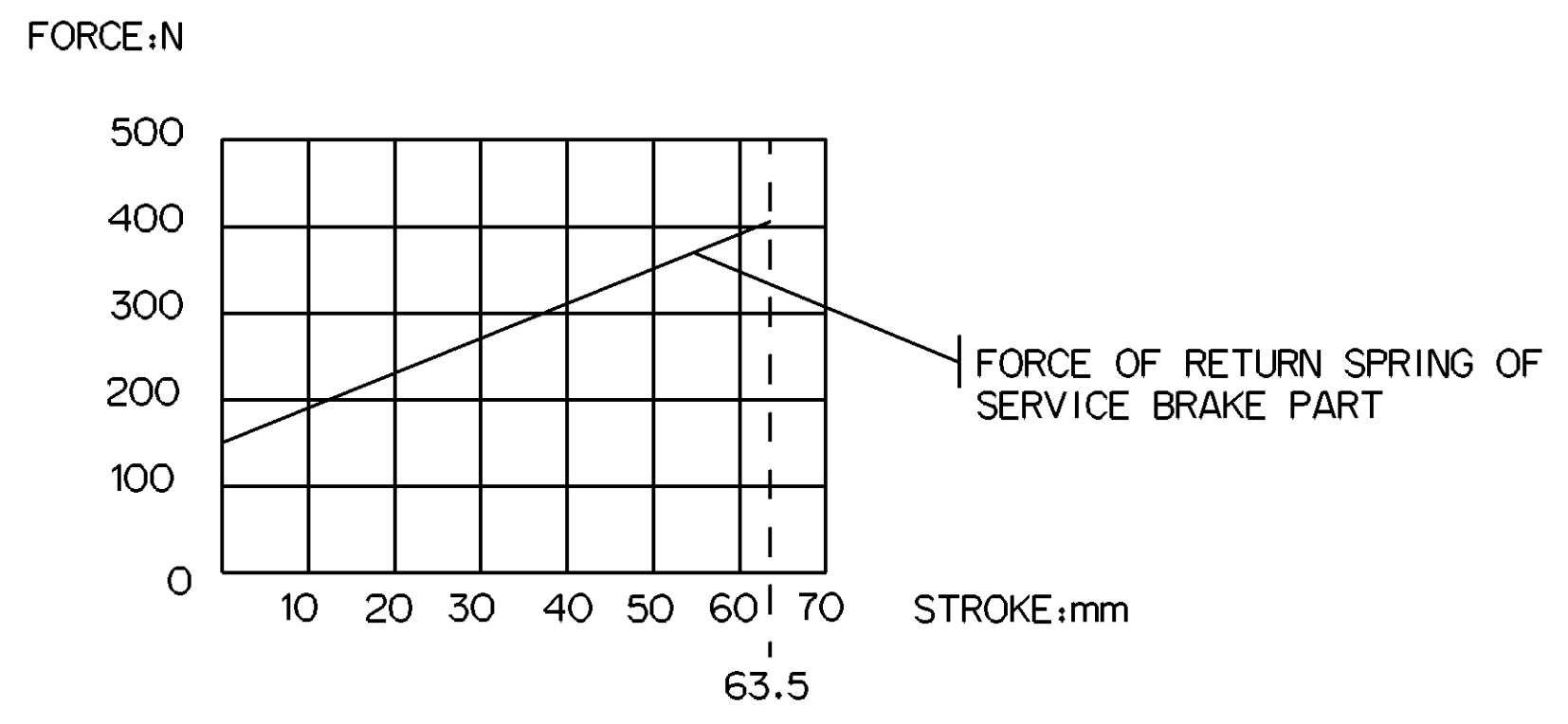
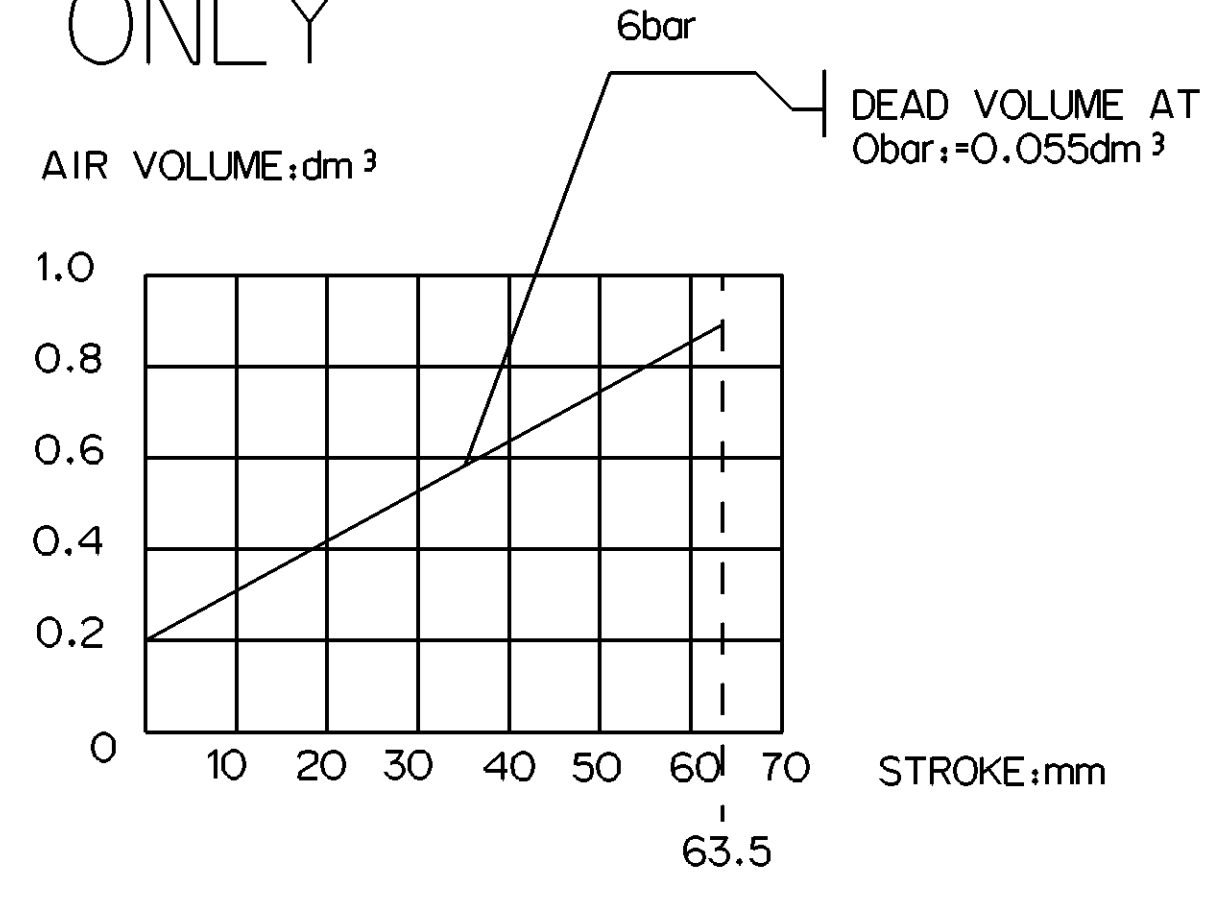
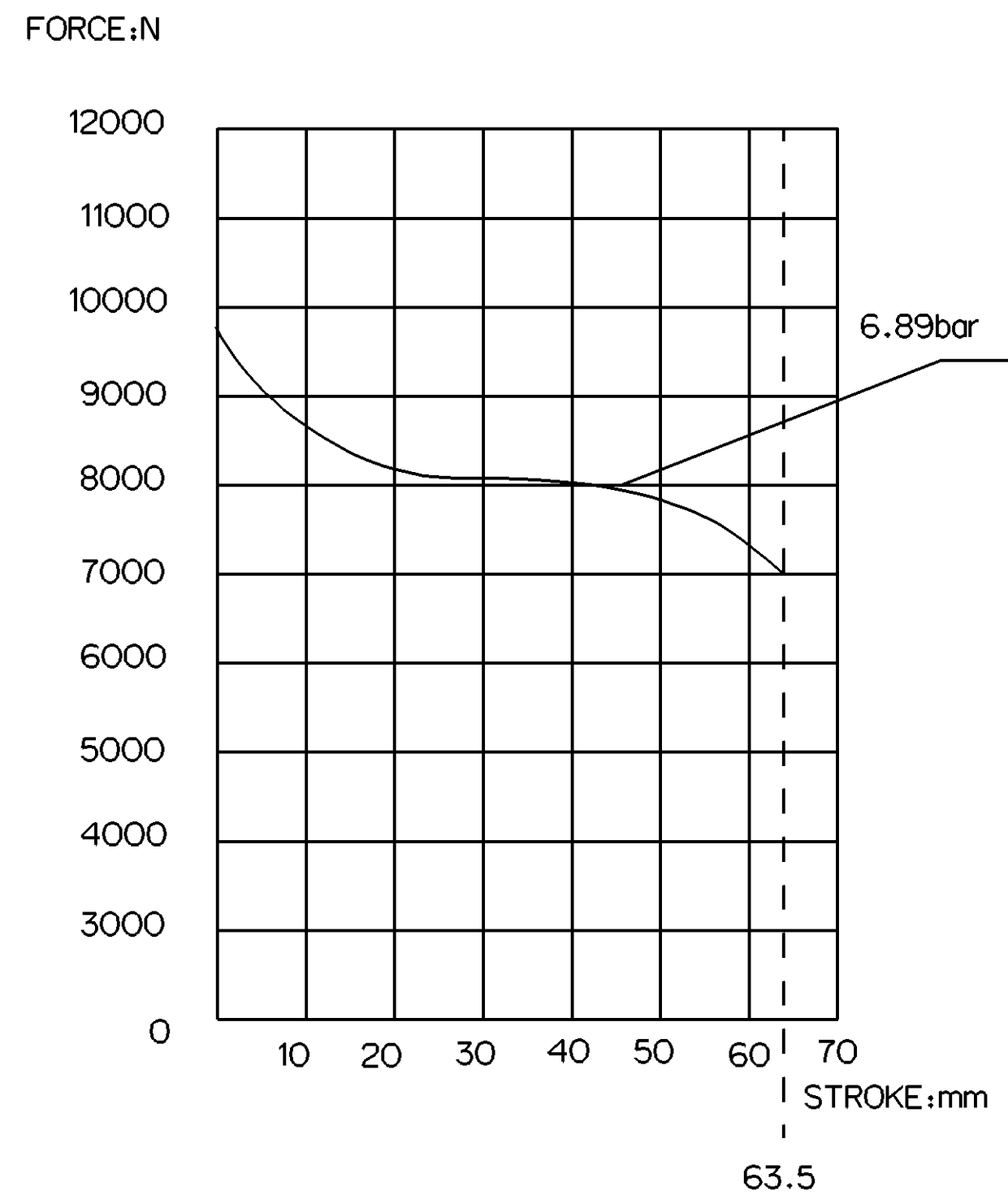

General Specifications: ISO 8015, JED-334-1, Size ISO 14405 LP		Copyright WABCO®	
Further Technical Data: PRO 714 033 0		Date	Signature
Doc. Code: 035	Sheet: 1 To 10	2023-04-27	Kariya
General Tolerances JED-261		Checked	
Range of Nominal Dimensions (± mm)		2023-04-27	
Class	1) ≤ 50	2) > 50 < 180	3) ≥ 180 < 400
Fine	±0.5	±1	±1.5
Medium	±1	±2	±3
Coarse	±2	±3.5	±5
Tapped Holes acc. -		Subbiah	
1) Tolerance Class Applied Crossmarked		Material No.	
Mass		Date of first issue: 2023-04-27	
3.4 kg		Doc. Code Language Sheet	
Scale		PRO 714 036 0 005 EN 1/1	
1:1 (2:1)		Tech. Resp.	
Size CAD System		Ech. No. Revision	
A 1 CREO		5350_AM	

Non è permesso copiare o riprodurre questo documento, né utilizzare il contenuto in modo commerciale (art. 1772).
 Toute réimpression ou reproduction de ce document, sans autorisation écrite préalable, est formellement interdite.
 Copia di questo documento e ogni altro uso o comunicazione di questo contenuto, senza permesso scritto, sono espressamente vietati.
 All rights reserved. No part of this document may be reproduced or transmitted in any form or by any means electronic or mechanical, including photocopying and recording, or by any information storage or retrieval system, without prior written permission from WABCO.