

DRAFT FOR TEXT AREAS EXPLANATION ONLY. DRAFT CAN BE DIFFERENT TO THE REAL PART.

IDENTIFICATION	DESIGNATION	KIND OF MARKING	COLOUR	SIZE OF TYPES RESP. STANDARD	REMARKS
e	PROVIA - LOGO	TAMPON / UV-BRANDING	WHITE	SIZE 6	
f	PROVIA - SET NUMBER	TAMPON / UV-BRANDING	WHITE		
g	PROVIA - SALES REFERENCE, US-CODE (WHEN EXIST)	TAMPON / UV-BRANDING	WHITE		
h	NUMBER OF WVA	TAMPON / UV-BRANDING	WHITE	HEIGHT OF CHARACTERS 5±1MM HEIGHT OF CHARACTERS AND POSITION OF THE MARKING MAY BE ACC. TO THE SHAPE OF THE BACKING PLATE	
j	NUMBER OF ECE	TAMPON / UV-BRANDING	WHITE		
k	COUNTRY OF ORIGIN	TAMPON / UV-BRANDING	WHITE		
l	BATCH NUMBER	TAMPON / UV-BRANDING	WHITE		
m	ENVIRONMENTAL MARKING ACC. TO SAE J866 JUL2012 OR LATEST	TAMPON / UV-BRANDING	WHITE		

- (A) MAX. 10% LACQUER PERMITTED, WITHOUT MOULD SKIN. (ACC. TO FINISHING CODE)
- (B) FIRMLY ATTACHED BURR AROUND PAD CONTOUR PERMITTED, BUT IT MUST NOT PROTRUDE BEYOND BACKING PLATE.

POS.	NAME	QUANTITY
1	BRAKE PAD	4

General Specification: JED-334-1, Size ISO 14405 LP

Copyright WABCO®

Further Technical Data: Part Specification

Doc. Code: 014 Sheet: To

Date: 2018-07-18

Signature: Cabulo

Checked: Marcinkiewicz

Expert: Liszwan

Material No.: 340 902 191 2

Date of first issue: 2016-08-25

Doc. Code: 005 EN 1/2

Revision: 176942

Revision: 6 x B

Techn. Resp.: 0959

Replacement for: -

1) Tolerance Class Applied Crossmarked

100mm

Non è permesso copiare o riprodurre questo documento, né utilizzare il contenuto a fini commerciali, senza permesso scritto dalla WABCO. Tutti i diritti sono riservati.
 Toute réimpression ou reproduction de ce document, sans autorisation écrite préalable de WABCO, est formellement interdite.
 Wollt man dieses Dokument kopieren, ist dies ohne schriftliche Genehmigung von WABCO.
 All rights reserved.
 All rights reserved.
 All rights reserved.

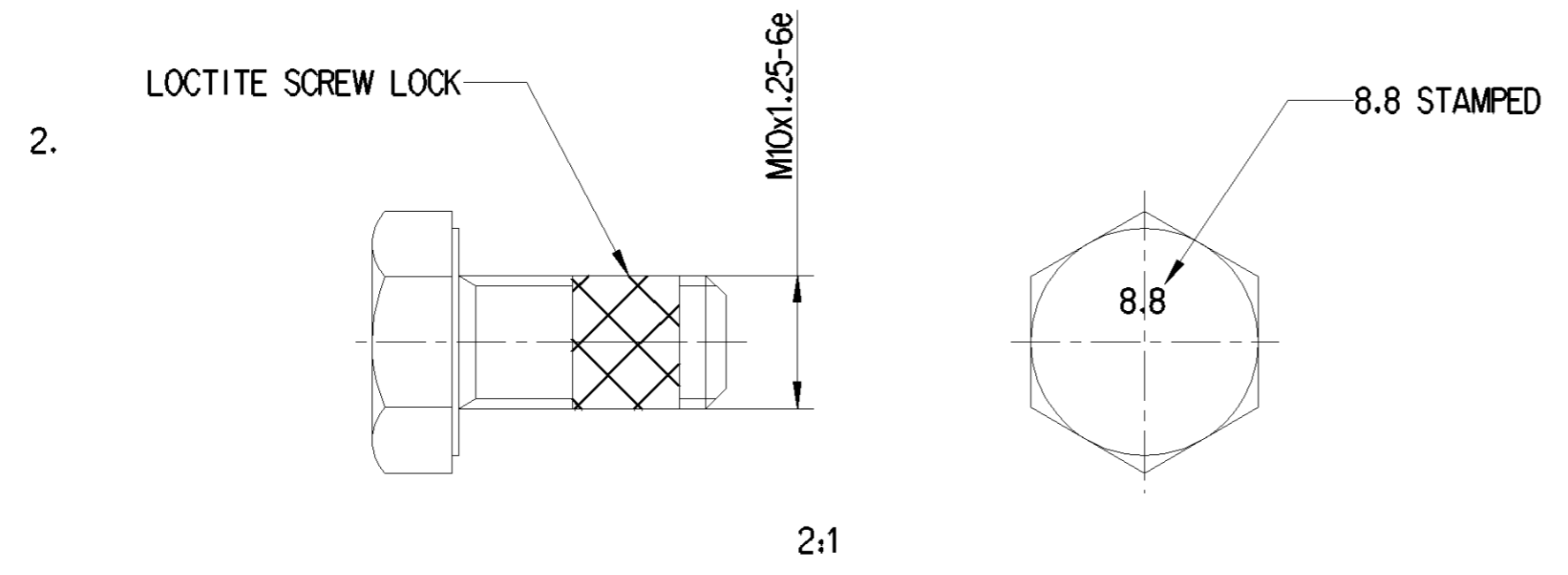
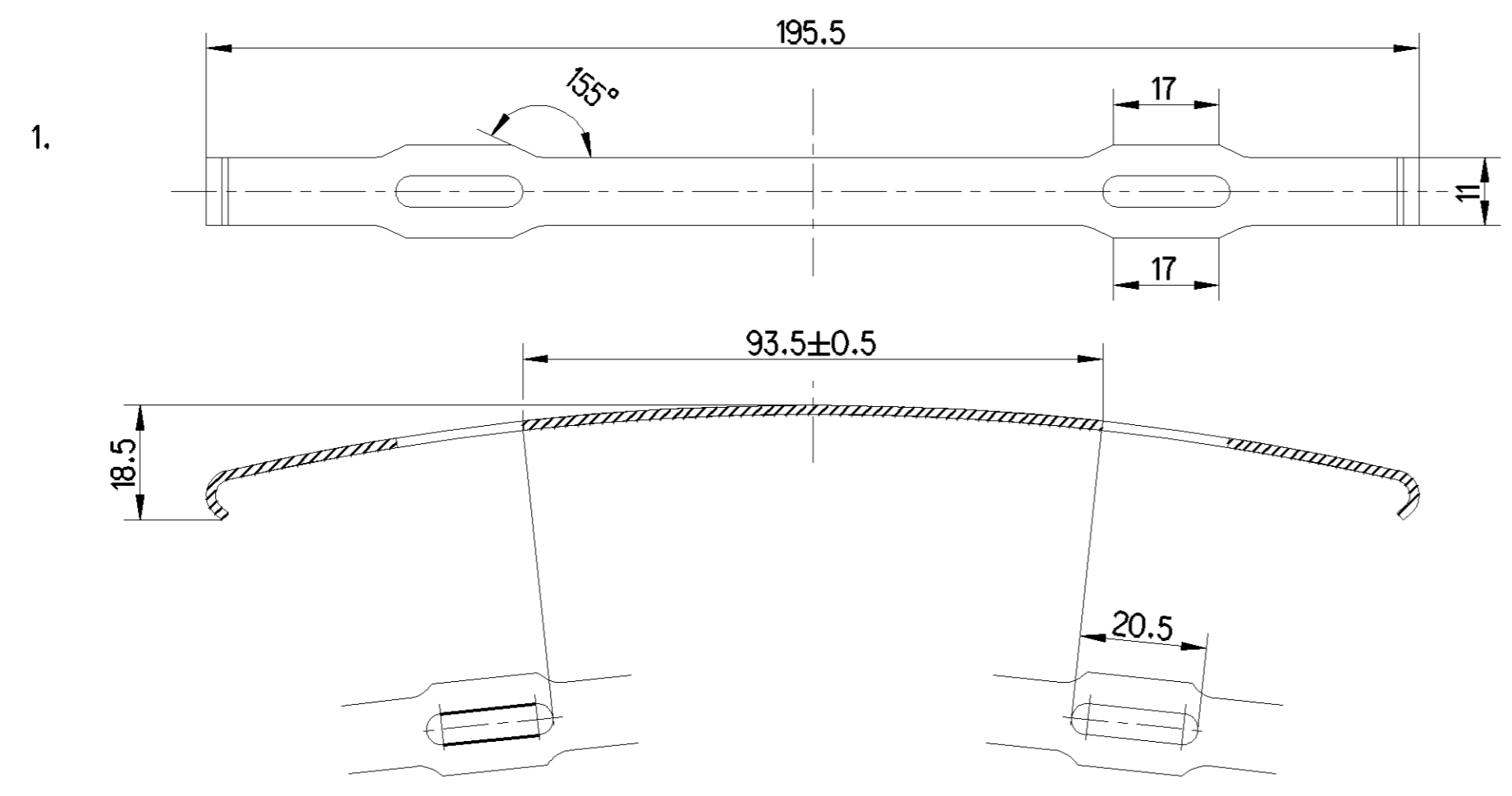

POS.	NAME	QUANTITY
1	SPRING	4
2	SCREW	2

General Specification: JED-334-1, Size ISO 14405 LP

Copyright WABCO®

Further Technical Data: Part Specification

Doc. Code: 014 Sheet: To

General Tolerances JED-261

Class	Range of Nominal Dimensions (± mm)				∠
	≤ 50	> 50 ≤ 180	> 180 ≤ 400	> 400	
Fine	0.5	1.0	1.5	2.0	±3°
Medium	1.0	2.0	3.0	4.0	
Coarse	2.0	3.5	5.0	6.5	

Tapped Holes acc.

1) Tolerance Class Applied Crossmarked

Mass: 0.5 kg Scale: 1:1 (2:1)

Size: A 2 CREO

Material No.: 340 902 191 2

Date of first issue: 2016-08-25

Doc. Code: 005 Language: EN Sheet: 2/2

ECN-No.: 176942 Revision: 6 x B Techn. Resp.: 0959 Replacement for: -

ProVia PAD KIT

2018-07-18 Drawn: Cebula

2018-07-18 Checked: Marcinkiewicz

Expert: Liszwan

Non e permesso copiare, o terzi o riprodurre questo documento, ne utilizzare il contenuto o renderlo comunque noto a terzi senza autorizzazione esplicita. Ogni infrazione costituisce un evidente abuso e comportera il risarcimento dei danni subiti. E' fatta riserva di tutti i diritti derivanti da brevetti o modelli.

Copying of this document and giving it to others and the use or communication of the contents thereof, are forbidden without express authority. Contravention of this restriction will constitute an evident abuse and result in a liability to the payment of damages. All rights are reserved in the event of the grant of patent or registration of a utility model or design. This document is the subject of copyright.

Toutte communication ou reproduction de ce document, toute exploitation ou communication de son contenu sont interdites, sauf autorisation expresse. Tout manquement a cette regle constitue un abus evident et expose son auteur au versement de dommages et interets. Tous droits de proprieite industrielle reserves, notamment en matiere de brevets et de modesles.

Wiedergabe sowie Vervielfältigung dieser Unterlagen, Verwertung und Mitteilung ihres Inhalts nicht gestattet, soweit nicht ausdrücklich ansonsten, weitergegeben, stellen eine offensichtliche Missbrauch dar und verpflichten zu Schadensersatz. Alle Rechte hier den Fall der Patentierung oder Gebrauchsmuster-Eintragung vorbehalten.