

S.NO	MATERIAL	SURFACE PROTECTION
I	ALUMINIUM ALLOY	BALL BURNISH BRIGHT
II	NBR	NO TREATMENT
III	STEEL	ZINC PLATING
IV	STEEL	BLACK E-COAT
V	HDPE	NO TREATMENT

SAFETY CHARACTERISTICS	0
SIGNIFICANT CHARACTERISTICS	0
CUSTOMER INTERFACE	0

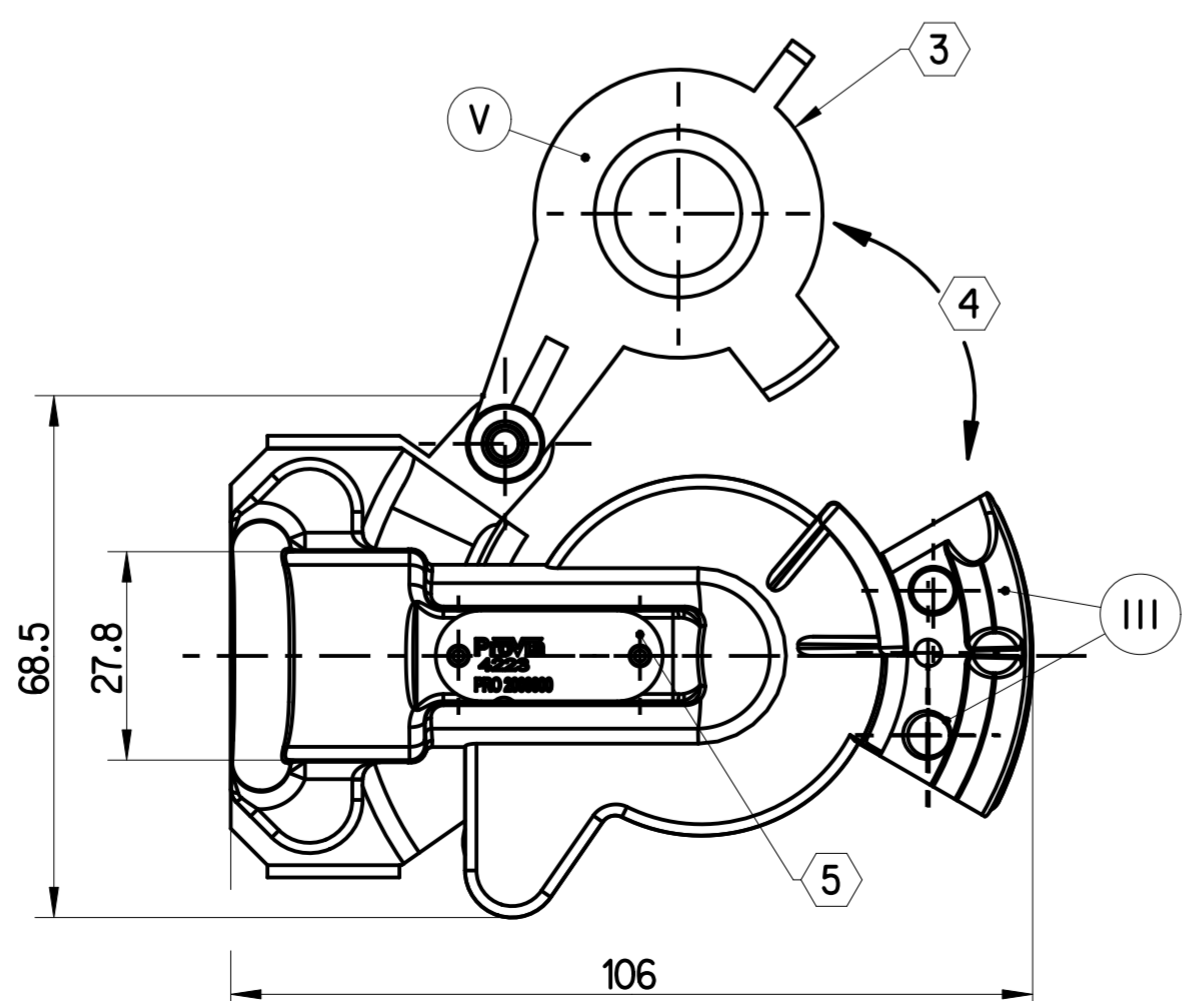
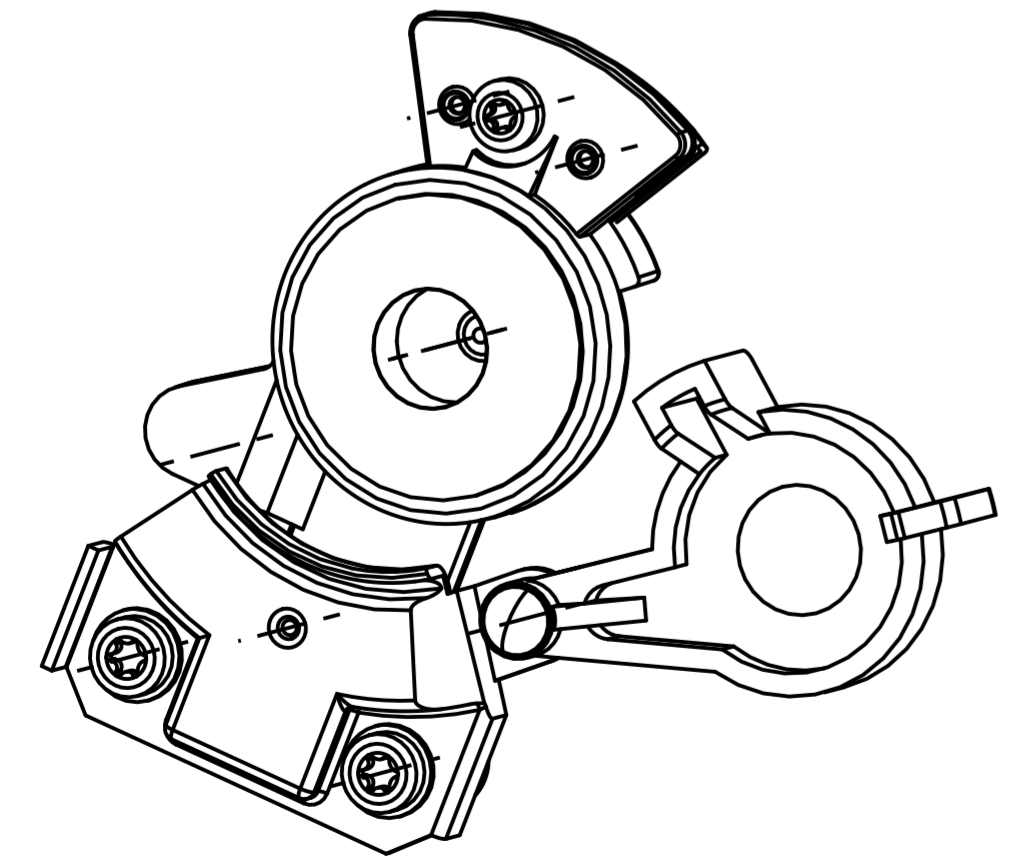
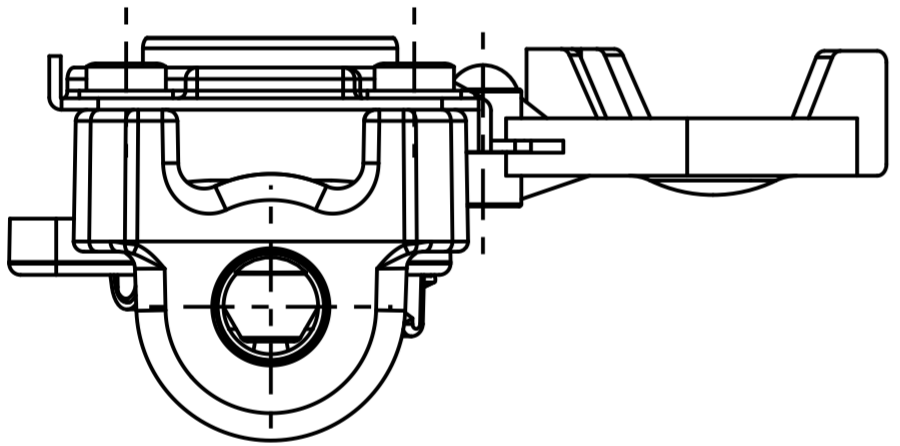
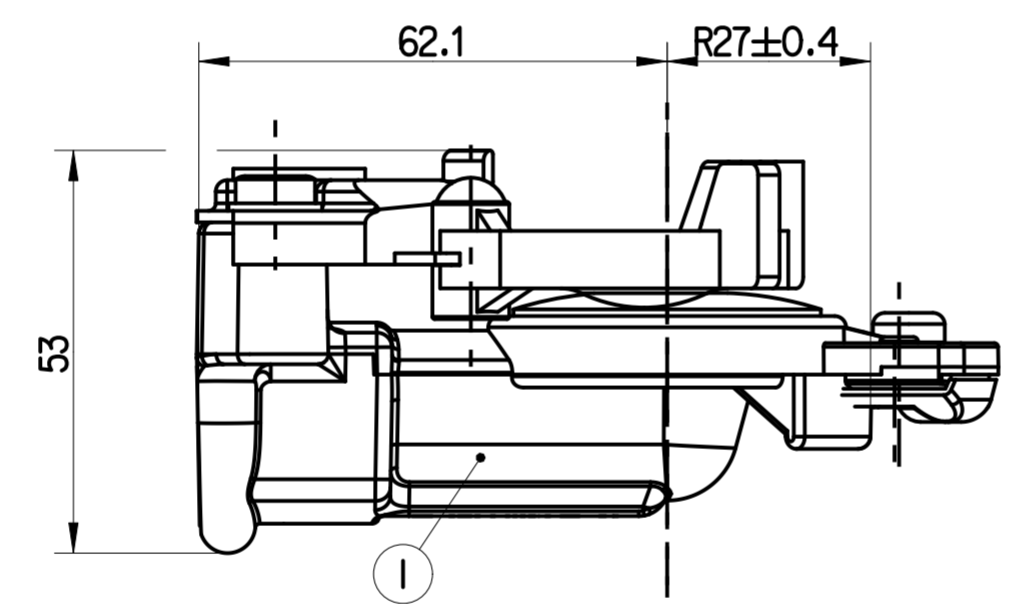
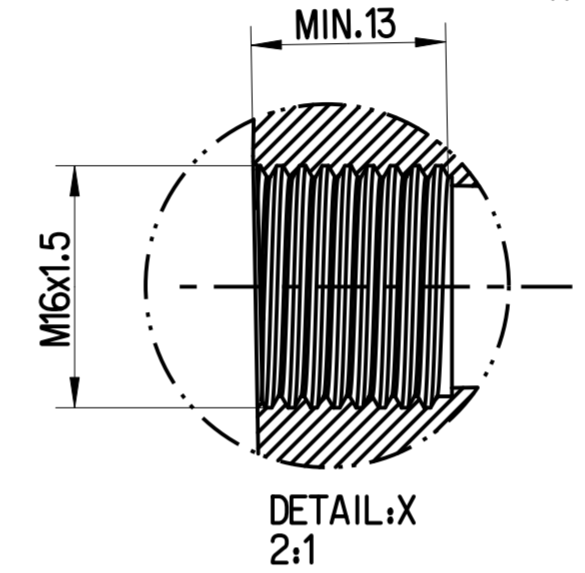
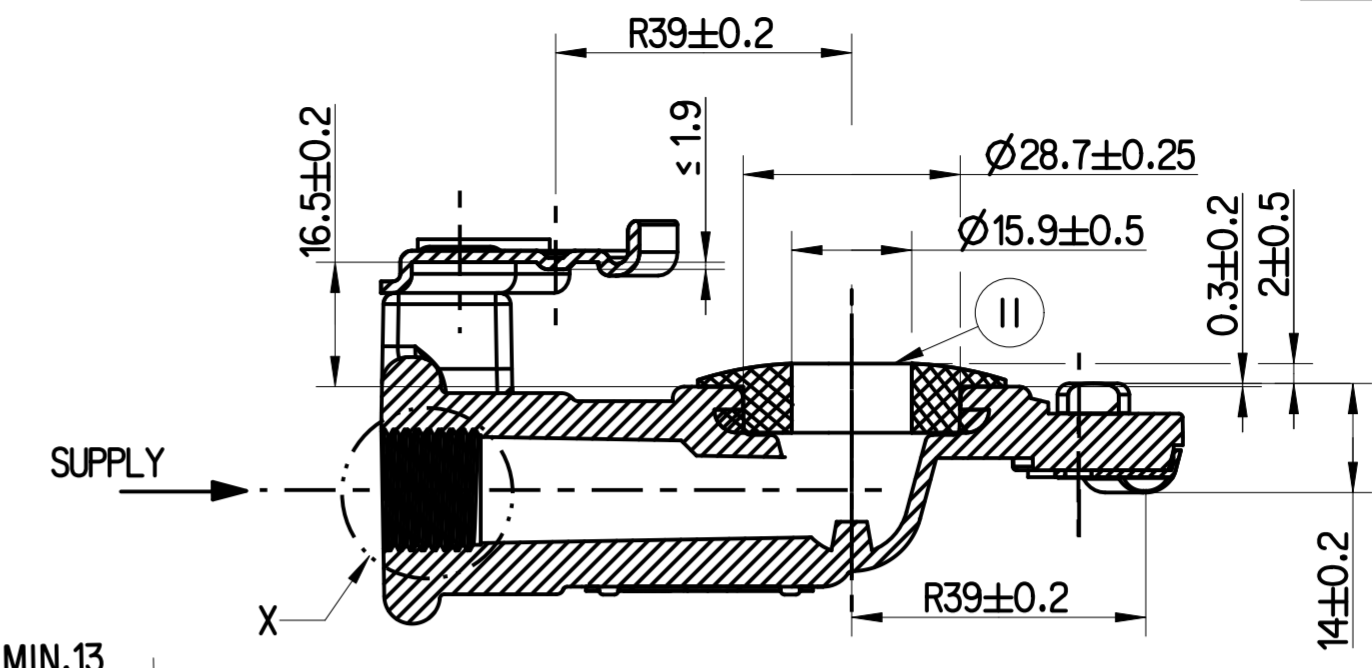
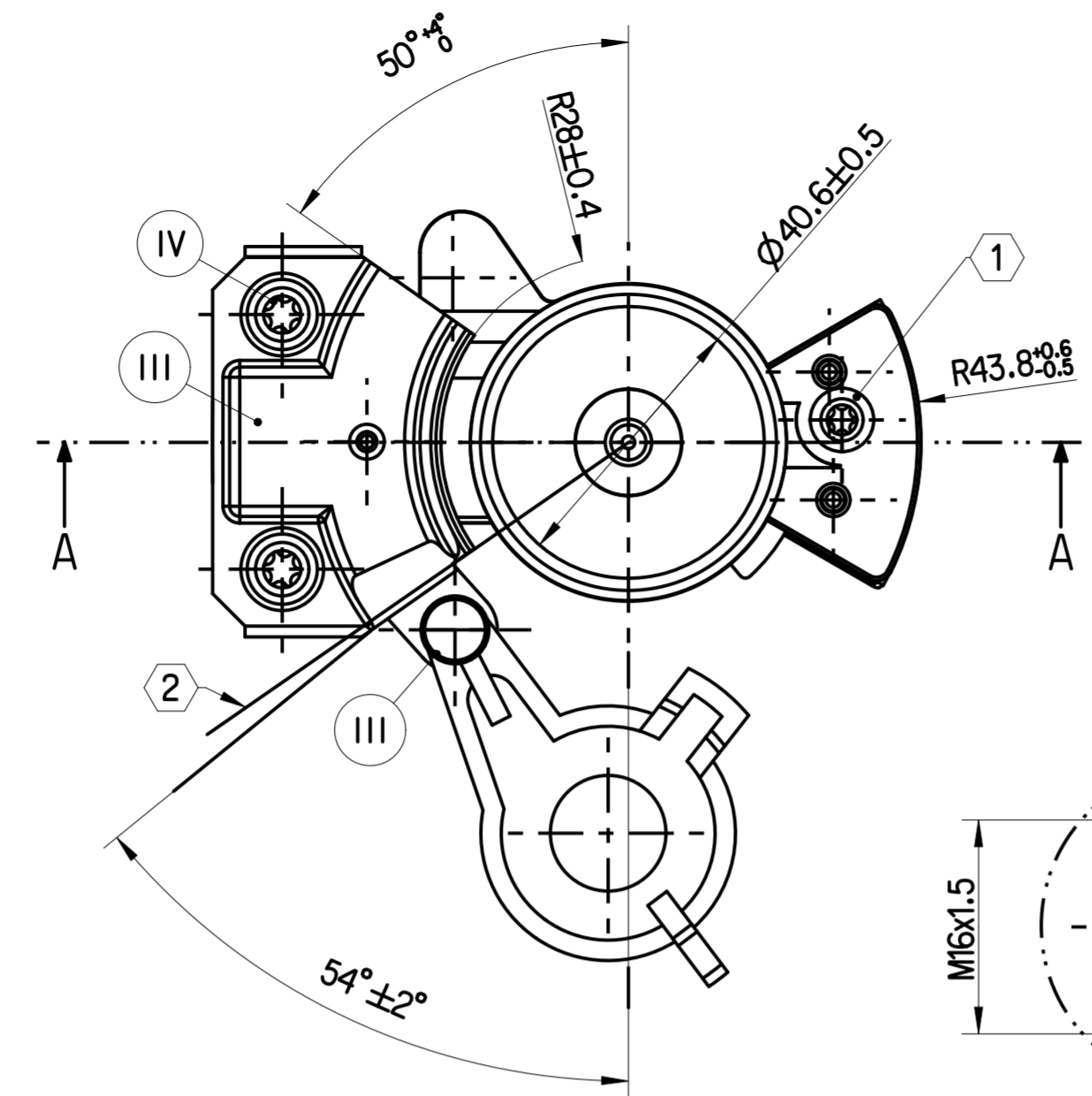

- NOTES
- 1 POKA-YOKE
 - 2 STOP
 - 3 LID COLOUR-RED
LID MUST BE CLOSED WHEN NOT IN USE
 - 4 DIRECTION OF LID ROTATION
 - 5 PART NUMBER AND DATE OF MANUFACTURE ARE SHOWN HERE.

S.No	NOTES	
1	WORKING MEDIUM	COMPRESSED AIR
4	WORKING TEMPERATURE	-40° C TO +70° C
5	MAXIMUM INLET PRESSURE	8.5 bar
6	RECOMMENDED INSTALLATION TORQUE	31±3 Nm (CUSTOMER TO ENSURE THE TORQUE)
7	TRACTOR AND TRAILER COUPLING FLOW DIAMETER IS EQUIVALENT AND MIN. FLOW PASSAGE	103mm ² (Ø11.4mm)
8	CIRCUIT DIAGRAM SYMBOL	ISO 1219
9	PART PRESSURE TIGHT UPTO	10 bar
10	RED COLOR COUPLING FOR SUPPLY SIDE	

General Specification: ISO 8015, JED-334-1, Size ISO 14405 LP		Copyright ZF®		ProVia	
Further Technical Data: PRO 200 000 0		Date	Signature		
Doc. Code: 035	Sheet: 1 To 9	2024-04-17	Kaviya	COUPLING HEAD TRACTOR SUPPLY	
General Tolerances JED-261		Checked	Saravanan		
Range of Nominal Dimensions (± mm)		Dimensions in mm		Material No.	
Class 1)	≤ 50 > 50 ≤ 180 > 180 ≤ 400 > 400	Mass	Scale	Date of first issue: 2024-04-23	
Fine	±0.5 ±1 ±1.5 ±2	0.175	NTS	PRO 200 012 0	
Medium	±1 ±2 ±3 ±4	kg		Doc.Code	Language
Coarse	±2 ±3.5 ±5 ±6.5	Size	CAD System	005	EN
Tapped Holes acc. -		A 2	CREO	Techn. Resp.	1/1
1) Tolerance Class Applied Crossmarked		ECN-No.	Revision	5710_AM	Replacement for

Non e permesso copiare, o terzi o riprodurre questo documento, ne utilizzare il contenuto o renderlo comunque noto o terzi senza autorizzazione esplicita. Ogni infrazione costituisce un evidente abuso e comportera il risarcimento dei danni subiti. E' fatta riserva di tutti i diritti derivanti da brevetti o modelli.

Toute communication ou reproduction de ce document, toute exploitation ou communication de son contenu sont interdites, sauf autorisation expresse. Tout manquement a cette regle constitue un abus evident et expose son auteur au versement de dommages et interets. Tous droits de propriete industrielle reserves, notamment en matiere de brevets et de modesles.

Copying of this document and giving it to others and the use or communication of the contents hereof, are forbidden without express authority. Contention of this restriction will constitute an evident cause and result in a liability to the payment of damages. All rights are reserved in the event of the grant of patent or registration of a utility model or design. This document is the subject of copyright.

Weitergabe sowie Vervielfaltigung dieser Unterlagen, Vervielfaltigen und Mitteilen ihres Inhalts nicht gestattet, soweit nicht ausdrücklich anders besprochen. Zuwiderhandlungen stellen einen offensichtlichen Missbrauch dar und verpflichten zu Schadensersatz. Alle Rechte fuer den Fall der Patenterteilung oder Gebrauchsmuster-Eintragung vorbehalten.