

Draft for text areas explanation only. Draft can be different to the real part.

Identifi- cation	Designation	Kind of Marking	Colour	Size of Types resp. Standard	Remarks
e	ProVia - Logo	Tampon / UV-branding	white	Size 6	
f	ProVia - Set number	Tampon / UV-branding	white	Height of characters 5 ±1 mm Height of characters and position of the marking may be acc. to the shape of the backing plate	
g	ProVia - Sales reference, US-Code (when exist)	Tampon / UV-branding	white		
h	Number of WVA	Tampon / UV-branding	white		
j	Number of ECE	Tampon / UV-branding	white		
k	Country of origin	Tampon / UV-branding	white		
l	Batch number	at markers option	white		
m	Environmental marking acc. to SAE J866 JUL2012 or latest	at markers option	white		

- a Max. 10% lacquer permitted, without mould skin.  
(acc. to finishing code)
- b Firmly attached burr around pad contour permitted,  
must not protrude beyond backing plate

Pos.	Name	Quantity
1	Brake pad	4

General Specification: JED-334-1 - Size ISO 14405 LP

Copyright WABCO®

Doc. Code: O14 Sheet: 1 To 4

Further Technical Data: PART SPECIFICATION

Date: 2017-12-11 Drawn: Liszwan

Checked: Przybyasz

Expert: Liszwan

Material No.: 340 322 000 2

Date of first issue: 2016-08-25

Doc. Code: 005 EN 1/2

Revision: 3x A

Techn. Resp.: 0959

Replacement for: -

Scale: 1:1

Size: A 1

CREO

1) Tolerance Class Applied Crossmarked

Non è permesso copiare o riprodurre questo documento, né utilizzare il contenuto a fini commerciali senza permesso scritto dalla WABCO. È vietata espressamente la ristampa o l'uso non autorizzato. Toute réimpression ou utilisation non autorisée sans la permission écrite de la WABCO est formellement interdite. Toute réimpression ou utilisation non autorisée sans la permission écrite de la WABCO est formellement interdite. All rights reserved. No part of this document may be reproduced, stored in a retrieval system or transmitted in any form or by any means electronic, mechanical, photocopying, recording, or by any information storage and retrieval system without the prior written permission of WABCO. All rights reserved. No part of this document may be reproduced, stored in a retrieval system or transmitted in any form or by any means electronic, mechanical, photocopying, recording, or by any information storage and retrieval system without the prior written permission of WABCO.

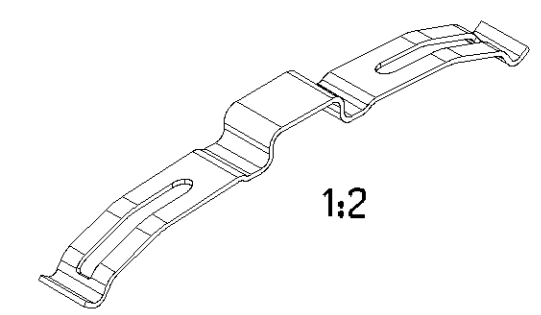
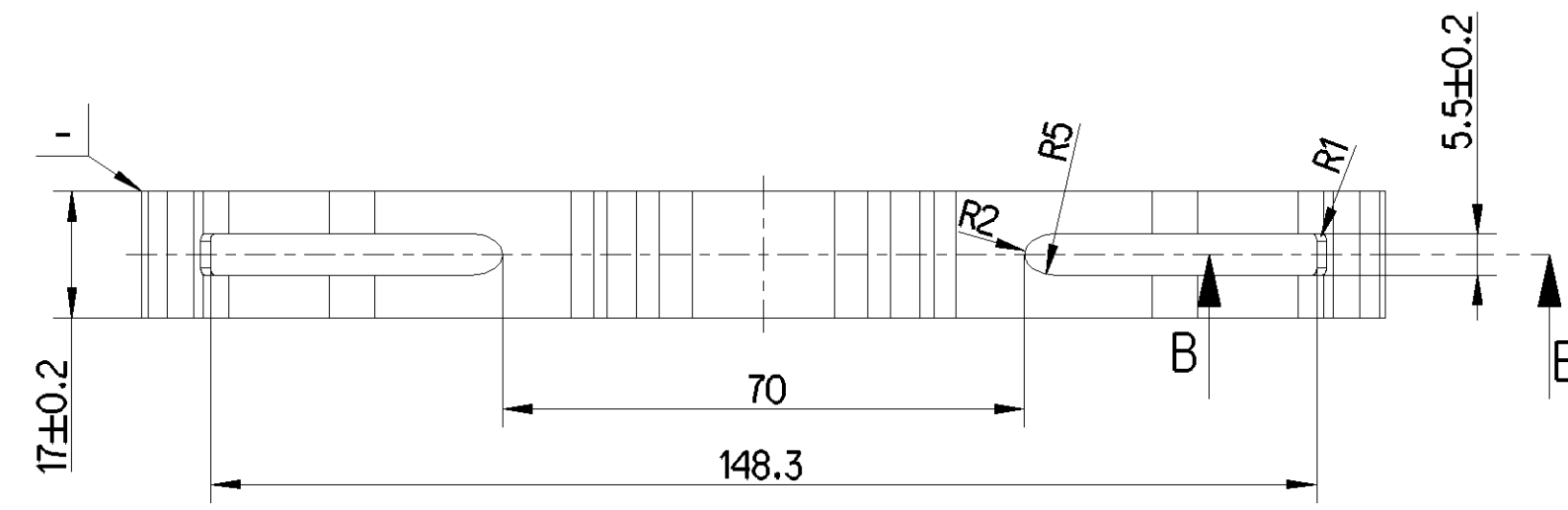
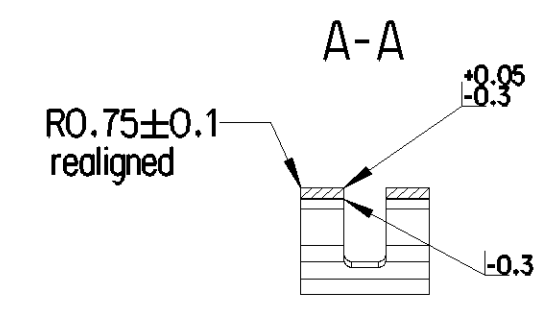
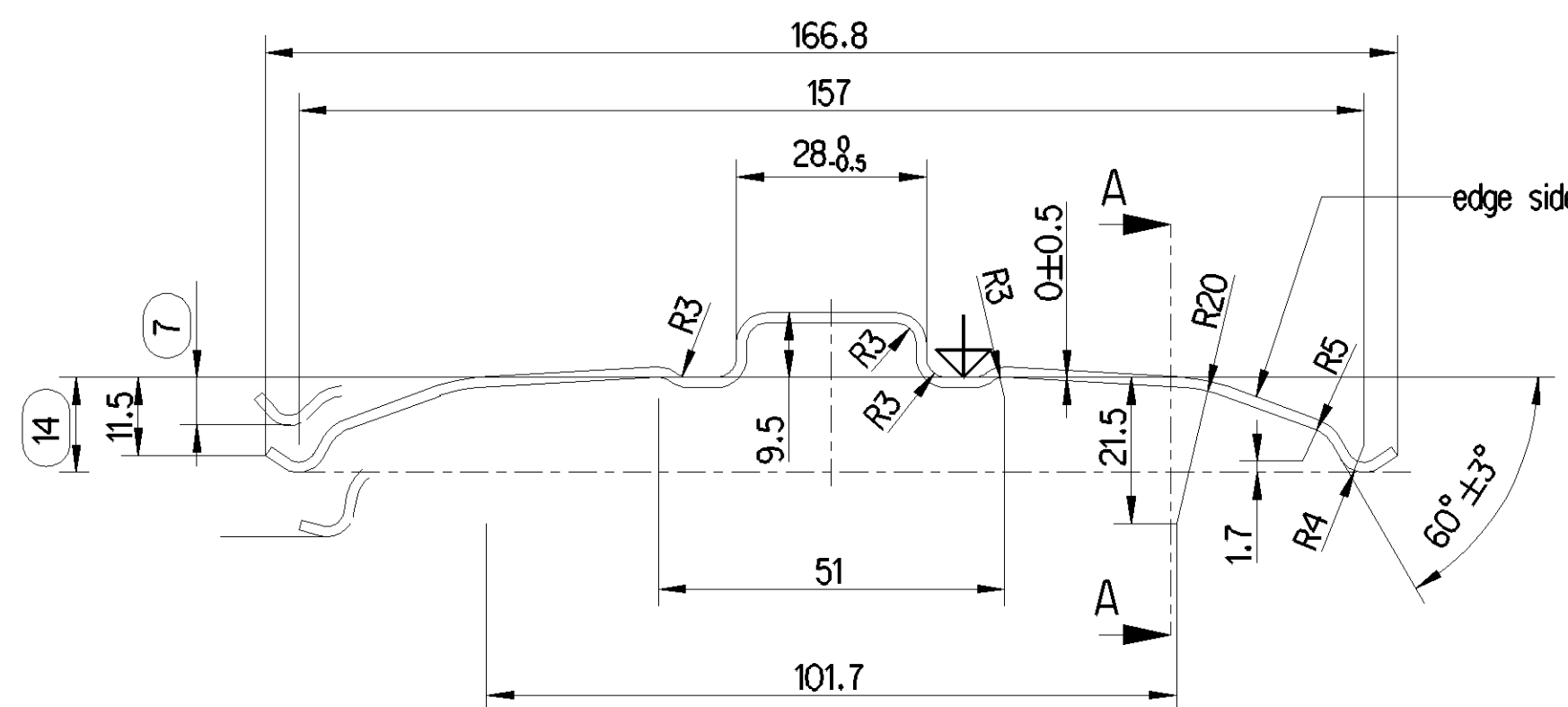

Pos.	Name	Quantity
1	Leaf spring MAXX22	6

General Specification: JED-334-1, Size ISO 14405 LP		Copyright WABCO®		<b>ProVia</b> Accessory Kit		
Further Technical Data:		Date	Signature			
Doc. Code:	Sheet: To	Drawn	Lisztwan			
General Tolerances JED-261		Checked	Przybysz			
Range of Nominal Dimensions ( ± mm)		Expert		Material No. 340 322 000 2		
Class 1)	≤ 50	> 50 ≤ 180	> 180 ≤ 400	> 400	±3°	Date of first issue: 2016-08-25
Fine	0.5	1.0	1.5	2.0	±3°	Doc.Code 005
Medium	1.0	2.0	3.0	4.0		Language EN
Coarse	2.0	3.5	5.0	6.5		Sheet 2/2
Tapped Holes acc.		Mass 0.5 KG	Scale 1:1	Replacement for -		
1) Tolerance Class Applied Crossmarked		Size A 3	CAD System CREO	ECN-No. 174602	Revision - A	Techn. Resp. 0959

Non e permesso consegnare a terzi o riprodurre questo documento, ne utilizzare il contenuto o renderlo comunque noto a terzi senza autorizzazione esplicita. Ogni infrazione costituirà un evidente abuso e comporterà il risarcimento dei danni subiti. E' fatto riserva di tutti i diritti derivanti da brevetti o modelli.

Man e permisso consegnare a terzi o riprodurre questo documento, ne utilizzare il contenuto o renderlo comunque noto a terzi senza autorizzazione esplicita. Ogni infrazione costituirà un evidente abuso e comporterà il risarcimento dei danni subiti. E' fatto riserva di tutti i diritti derivanti da brevetti o modelli.

Toute communication ou reproduction de ce document, toute exploitation ou communication de son contenu sont interdites, sauf autorisation expresse. Tout manquement a cette regle constitue un abus evident et expose son auteur au versement de dommages et interets. Tous droits de propriete industrielle reserves, notamment en matiere de brevets et de modesles.

Weitergabe sowie Vervielfaeligung dieser Unterlage, Verwertung und Mitteilung ihres Inhalts nicht gestattet, soweit nicht ausdruecklich zugestanden. Zuwiderhandlungen stellen einen offensaetlichen Misbrauch dar und verpflichten zu Schadenersatz. Alle Rechte fuer den Fall der Patenterteilung oder Gebrauchsmuster-Eintragung vorbehalten.